

VSI OpenVMS

VSI TCP/IP Services for OpenVMS User's Guide

Document Number: DO-TCPUSR-01A

Publication Date: September 2021

Revision Update Information: This is a new manual.

Operating System and Version: VSI OpenVMS Integrity Version 8.4-2
VSI OpenVMS Alpha Version 8.4-2L1

Software Version: VSI TCP/IP Services Version 5.7

VSI TCP/IP Services for OpenVMS User's Guide



VMS Software

Copyright © 2021 VMS Software, Inc. (VSI), Burlington, Massachusetts, USA

Legal Notice

Confidential computer software. Valid license from VSI required for possession, use or copying. Consistent with FAR 12.211 and 12.212, Commercial Computer Software, Computer Software Documentation, and Technical Data for Commercial Items are licensed to the U.S. Government under vendor's standard commercial license.

The information contained herein is subject to change without notice. The only warranties for VSI products and services are set forth in the express warranty statements accompanying such products and services. Nothing herein should be construed as constituting an additional warranty. VSI shall not be liable for technical or editorial errors or omissions contained herein.

HPE, HPE Integrity, HPE Alpha, and HPE Proliant are trademarks or registered trademarks of Hewlett Packard Enterprise.

Intel, Itanium and IA-64 are trademarks or registered trademarks of Intel Corporation or its subsidiaries in the United States and other countries.

UNIX is a registered trademark of The Open Group.

| | |
|---|------------|
| Preface | vii |
| 1. About VSI | vii |
| 2. Intended Audience | vii |
| 3. Document Structure | vii |
| 4. Related Documents | viii |
| 5. VSI Encourages Your Comments | ix |
| 6. Conventions | ix |
| Chapter 1. Getting Started | 1 |
| 1.1. Which Service Should You Use? | 3 |
| 1.1.1. Services for Working with Files | 5 |
| 1.1.2. Services for Remote Logins | 5 |
| 1.1.3. Services for Issuing Commands at a Remote Host | 6 |
| 1.2. Client/Server Software | 6 |
| 1.3. User Commands | 7 |
| 1.4. Command Syntax | 8 |
| 1.5. Online Help | 10 |
| Chapter 2. Working with Files Using the File Transfer Protocol (FTP) | 13 |
| 2.1. Using FTP Commands | 16 |
| 2.1.1. DCL and UNIX Command Syntax | 16 |
| 2.1.2. Quotation Marks | 17 |
| 2.1.3. Wildcards | 17 |
| 2.1.4. Qualifiers | 18 |
| 2.2. Obtaining Online Help | 18 |
| 2.3. Starting FTP Sessions | 19 |
| 2.3.1. Making a Remote Connection | 19 |
| 2.3.2. Anonymous User Access (Anonymous FTP) | 20 |
| 2.4. Exiting FTP | 21 |
| 2.5. Viewing Directories on the Remote Host | 22 |
| 2.6. Displaying and Changing the Default Directory | 22 |
| 2.7. Creating and Deleting Directories | 23 |
| 2.8. Copying Files | 23 |
| 2.8.1. Using the GET Command to Copy Remote Files to the Local Host | 23 |
| 2.8.2. Using the PUT Command to Copy Local Files to the Remote Host | 24 |
| 2.8.3. How FTP Copies Files | 25 |
| 2.8.4. Using the Store Unique Feature | 26 |
| 2.8.5. Transferring Files Between OpenVMS Hosts: VMS Plus Mode | 26 |
| 2.8.6. Preserving OpenVMS File Attributes | 26 |
| 2.8.7. Transfer Mode | 28 |
| 2.8.8. File Structure | 28 |
| 2.9. Renaming and Deleting Files | 28 |
| 2.10. Viewing the Contents of a File | 28 |
| 2.11. Appending Files | 29 |
| 2.12. Suspending FTP to Return to the Local DCL Prompt | 29 |
| 2.13. Customizing FTP Command Processing | 30 |
| 2.14. Command Procedures | 31 |
| 2.14.1. Task Command Files | 31 |
| 2.14.2. Initialization Command File | 32 |
| 2.14.3. Setting Error Level | 33 |
| 2.15. Using FTP with DECnet | 34 |
| 2.16. Command Descriptions | 34 |
| Chapter 3. Using Remote (R) Commands | 63 |

| | |
|---|-----------|
| 3.1. Providing Account and Password Information | 63 |
| 3.1.1. Quotation Marks | 65 |
| 3.1.2. Examples | 65 |
| 3.2. Specifying Qualifiers | 65 |
| 3.3. Obtaining Online Help | 66 |
| 3.4. Copying Files with RCP | 66 |
| 3.4.1. Notes About File Formats | 67 |
| 3.4.2. Notes About File Size | 67 |
| 3.4.3. Example RCP Commands | 67 |
| 3.5. Starting a Remote Login Session with RLOGIN | 68 |
| 3.5.1. Logging Out | 68 |
| 3.5.2. Example RLOGIN Sessions | 68 |
| 3.6. Issuing a Remote Command with RSH | 69 |
| 3.6.1. Quotation Marks in Commands | 69 |
| 3.6.2. Interrupting a Command's Execution | 70 |
| 3.6.3. Example RSH Commands | 70 |
| 3.7. Issuing a Remote Command with a Password (REXEC Feature) | 71 |
| 3.7.1. Example of Using REXEC | 71 |
| 3.8. Command Descriptions | 71 |
| Chapter 4. Establishing Network Terminal Sessions Using TELNET/TN3270 | 85 |
| 4.1. Typing TELNET/TN3270 Commands | 88 |
| 4.1.1. DCL and UNIX Command Formats | 88 |
| 4.1.2. Quotation Marks | 89 |
| 4.2. Obtaining Online Help | 89 |
| 4.3. Starting TELNET and TN3270 | 90 |
| 4.3.1. Establishing Kerberos-Based Secure Connections | 90 |
| 4.4. Exiting TELNET and TN3270 | 92 |
| 4.5. Keeping a Log of Your TELNET Session | 92 |
| 4.6. Command Procedures | 92 |
| 4.6.1. Starting TELNET/TN3270 | 93 |
| 4.6.2. Initialization Command Files | 93 |
| 4.7. Toggling Between the Remote Host and Local TELNET/TN3270 | 93 |
| 4.8. Suspending TELNET to Return to the Local DCL Prompt | 96 |
| 4.9. Multiple Sessions | 96 |
| 4.9.1. Toggling Between Open Sessions | 97 |
| 4.9.2. Displaying Session Information | 98 |
| 4.10. Customizing TELNET/TN3270 Transmissions, Control Characters, and Displays | 98 |
| 4.11. Sending Commands to the Connected Remote Host | 100 |
| 4.12. IBM 3270 Model Terminal Emulation (TN3270) | 101 |
| 4.12.1. Supported IBM Terminal Models | 101 |
| 4.12.2. Setting Up Your PC or Terminal for IBM 3270 Terminal Emulation | 101 |
| 4.12.3. Starting and Exiting from TN3270 | 103 |
| 4.12.4. Clearing Error Messages | 104 |
| 4.12.5. Recording Sessions | 104 |
| 4.12.6. Online Help | 105 |
| 4.12.7. If the Keyboard Locks | 105 |
| 4.12.8. Keyboard Functions | 105 |
| 4.12.9. Redefining Your Keyboard | 116 |
| 4.12.10. Debugging Application Programs Using the IBM 3270 Model Terminal Emulator | 121 |
| 4.13. Command Descriptions | 122 |

| | |
|---|------------|
| Chapter 5. Sending and Receiving Mail Using SMTP | 161 |
| 5.1. Obtaining Online Help | 161 |
| 5.2. Sending Mail | 161 |
| 5.3. Specifying the SMTP Outbound Alias | 163 |
| 5.3.1. Defining the Outbound Alias | 163 |
| 5.3.2. Appending the Personal Name String to the Outbound Alias | 164 |
| 5.3.3. Appending a Substitute Domain String | 164 |
| 5.3.4. Disabling Modifications to TCPIP\$SMTP_FROM | 165 |
| 5.3.5. TCPIP\$SMTP_FROM and the Return-Path: Header | 165 |
| 5.3.6. X-VMS-True-From: Header | 165 |
| 5.3.7. Managing Outbound Alias Processing | 165 |
| 5.4. Sending Mail to Multiple Users | 166 |
| 5.4.1. Entering a List of Names | 166 |
| 5.4.2. Distribution Lists | 166 |
| 5.5. Reading Mail | 168 |
| 5.6. OpenVMS Mail Personal Name String | 169 |
| 5.7. Carbon-Copying Messages | 169 |
| 5.8. Forwarding Messages | 170 |
| 5.9. SMTP SFF (Send From File) | 170 |
| 5.9.1. Format of the SFF File | 170 |
| 5.9.2. SFF File Requirements | 171 |
| 5.9.3. SFF Security Measures | 172 |
| 5.9.4. Invoking SFF from an Application | 172 |
| 5.9.5. Invoking SFF from DCL | 172 |
| 5.10. Routing Mail with the UNIX-to-UNIX Copy Program | 173 |
| 5.10.1. Dialup Connections | 173 |
| 5.11. Management Commands for Mail | 173 |
| 5.11.1. Displaying SMTP Mail Status Information | 174 |
| 5.11.2. Deleting Holding State Mail Messages from SMTP Queues | 175 |
| 5.11.3. Releasing Holding State SMTP Mail Messages for Delivery | 175 |
| 5.12. Using Mail on Your PC | 176 |
| 5.12.1. POP | 176 |
| 5.12.2. IMAP | 176 |
| Chapter 6. Printing Files Using LPR/LPD | 187 |
| 6.1. Printing at Remote Print Queues | 187 |
| 6.1.1. PRINT /FORM Command | 188 |
| 6.1.2. PRINT /PARAMETERS Command | 188 |
| 6.1.3. Remote Queue Printing Examples | 190 |
| 6.2. Displaying the Status of Jobs in a Remote Print Queue | 190 |
| 6.3. Removing Jobs from the Print Queue | 191 |
| 6.4. Printing Remote UNIX Files on Local Queues | 191 |
| 6.5. Obtaining Online Help | 192 |
| 6.6. Command Descriptions | 192 |
| Chapter 7. Accessing User Information Using the FINGER Utility | 195 |
| 7.1. Typing FINGER Commands | 195 |
| 7.1.1. Wildcards | 195 |
| 7.1.2. Qualifiers | 196 |
| 7.2. Obtaining Online Help | 196 |
| 7.3. Displaying Information about Users | 196 |
| 7.3.1. Displaying Information about All Users | 197 |
| 7.3.2. Displaying Detailed Information about Specific Users | 197 |

| | |
|---|-----|
| 7.3.3. Displaying Information about Users on Your Cluster | 199 |
| 7.4. Forwarding Information from Host to Host | 201 |
| 7.5. Making Your Information Available to Other Users | 201 |
| 7.6. Command Description | 201 |

Preface

The TCP/IP Services product is the VSI implementation of the TCP/IP networking protocol suite and internet services for OpenVMS Alpha and OpenVMS VAX systems.

TCP/IP Services provides a comprehensive suite of functions and applications that support industry-standard protocols for heterogeneous network communications and resource sharing.

This manual explains how to use the user utilities and commands provided with the TCP/IP Services product. It assumes that these services have been installed and configured on your OpenVMS system and that you have a basic understanding of the OpenVMS operating system.

See the *VSI TCP/IP Services for OpenVMS Installation and Configuration* manual for information about installing, configuring, and starting this product.

1. About VSI

VMS Software, Inc. (VSI) is an independent software company licensed by Hewlett Packard Enterprise to develop and support the OpenVMS operating system.

VSI seeks to continue the legendary development prowess and customer-first priorities that are so closely associated with the OpenVMS operating system and its original author, Digital Equipment Corporation.

2. Intended Audience

This manual is for OpenVMS users who want to communicate with remote hosts on a private internet or on the worldwide Internet.

3. Document Structure

This manual contains following chapters:

- Chapter 1 introduces the services included in the TCP/IP Services product and explains how to enter command lines to use these services.
- Chapter 2 explains how to use FTP and provides FTP command descriptions.
- Chapter 3 explains how to use Remote Copy, Remote Login, Remote Shell, and Remote Execute and provides command descriptions.
- Chapter 4 explains how to use TELNET and IBM 3270 model terminal emulation (TN3270, using TELNET) and provides command descriptions.
- Chapter 5 explains how to use SMTP to send and receive electronic mail.
- Chapter 6 explains how to use LPR/LPD for remote printing and provides command descriptions.
- Chapter 7 explains how to use the FINGER utility to display information about users on a remote or local host.

4. Related Documents

The table below lists the documents available with this version of TCP/IP Services.

Table 1. TCP/IP Services Documentation

| Manual | Contents |
|--|--|
| <i>VSI TCP/IP Services for OpenVMS Concepts and Planning</i> | This manual provides conceptual information about TCP/IP networking on OpenVMS systems, including general planning issues to consider before configuring your system to use the TCP/IP Services software. This manual also describes the manuals in the TCP/IP Services documentation set and provides a glossary of terms and acronyms for the TCP/IP Services software product. |
| <i>VSI TCP/IP Services for OpenVMS Installation and Configuration</i> | This manual explains how to install and configure the TCP/IP Services product. |
| <i>VSI TCP/IP Services for OpenVMS User's Guide</i> | This manual describes how to use the applications available with TCP/IP Services such as remote file operations, email, TELNET, TN3270, and network printing. |
| <i>VSI TCP/IP Services for OpenVMS Management</i> | This manual describes how to configure and manage the TCP/IP Services product. |
| <i>VSI TCP/IP Services for OpenVMS Management Command Reference</i> | This manual describes the TCP/IP Services management commands. |
| <i>VSI TCP/IP Services for OpenVMS ONC RPC Programming</i> | This manual presents an overview of high-level programming using open network computing remote procedure calls (ONC RPC). This manual also describes the RPC programming interface and how to use the RPCGEN protocol compiler to create applications. |
| <i>VSI TCP/IP Services for OpenVMS Sockets API and System Services Programming</i> | This manual describes how to use the Sockets API and OpenVMS system services to develop network applications. |
| <i>VSI TCP/IP Services for OpenVMS SNMP Programming and Reference</i> | This manual describes the Simple Network Management Protocol (SNMP) and the SNMP application programming interface (eSNMP). It describes the subagents provided with the TCP/IP Services, utilities provided for managing subagents, and how to build your own subagents. |
| <i>VSI TCP/IP Services for OpenVMS Guide to IPv6</i> | This manual describes the IPv6 environment, the roles of systems in this environment, the types and function of the different IPv6 addresses, and how to configure TCP/IP Services to access the IPv6 network. |

For a comprehensive overview of the TCP/IP protocol suite, refer to the book *Internetworking with TCP/IP: Principles, Protocols, and Architecture*, by Douglas Comer.

5. VSI Encourages Your Comments

You may send comments or suggestions regarding this manual or any VSI document by sending electronic mail to the following Internet address: <docinfo@vmssoftware.com>. Users who have OpenVMS support contracts through VSI can contact <support@vmssoftware.com> for help with this product.

6. Conventions

The following conventions may be used in this manual:

| Convention | Meaning |
|-----------------------|--|
| Ctrl/ <i>x</i> | A sequence such as Ctrl/ <i>x</i> indicates that you must hold down the key labeled Ctrl while you press another key or a pointing device button. |
| PF1 <i>x</i> | A sequence such as PF1 <i>x</i> indicates that you must first press and release the key labeled PF1 and then press and release another key or a pointing device button. |
| Return | In examples, a key name enclosed in a box indicates that you press a key on the keyboard. (In text, a key name is not enclosed in a box.) |
| . . . | A horizontal ellipsis in examples indicates one of the following possibilities: <ul style="list-style-type: none"> • Additional optional arguments in a statement have been omitted. • The preceding item or items can be repeated one or more times. • Additional parameters, values, or other information can be entered. |
| | A vertical ellipsis indicates the omission of items from a code example or command format; the items are omitted because they are not important to the topic being discussed. |
| () | In command format descriptions, parentheses indicate that you must enclose the options in parentheses if you choose more than one. |
| [] | In command format descriptions, brackets indicate optional choices. You can choose one or more items or no items. Do not type the brackets on the command line. However, you must include the brackets in the syntax for OpenVMS directory specifications and for a substring specification in an assignment statement. |
| [] | In command format descriptions, vertical bars separate choices within brackets or braces. Within brackets, the choices are options; within braces, at least one choice is required. Do not type the vertical bars on the command line. |
| { } | In command format descriptions, braces indicate required choices; you must choose at least one of the items listed. Do not type the braces on the command line. |
| bold text | This typeface represents the introduction of a new term. It also represents the name of an argument, an attribute, or a reason. |
| <i>italic text</i> | Italic text indicates important information, complete titles of manuals, or variables. Variables include information that varies in system output (Internal error <i>number</i>), in command lines (/PRODUCER= <i>name</i>), and in command parameters in text (where <i>dd</i> represents the predefined code for the device type). |

| Convention | Meaning |
|-------------------|--|
| UPPERCASE TEXT | Uppercase text indicates a command, the name of a routine, the name of a file, or the abbreviation for a system privilege. |
| Monospace type | Monospace type indicates code examples and interactive screen displays. In the C programming language, monospace type in text identifies the following elements: keywords, the names of independently compiled external functions and files, syntax summaries, and references to variables or identifiers introduced in an example. |
| - | A hyphen at the end of a command format description, command line, or code line indicates that the command or statement continues on the following line. |
| numbers | All numbers in text are assumed to be decimal unless otherwise noted. Nondecimal radices—binary, octal, or hexadecimal—are explicitly indicated. |

Other conventions are:

- All numbers are decimal unless otherwise noted.
- All Ethernet addresses are hexadecimal.

Chapter 1. Getting Started

TCP/IP is an open communications standard that enables any connected host to communicate with any other connected host. The TCP/IP Services software is the VSI OpenVMS implementation of industry-standard TCP/IP networking protocols.

The TCP/IP Services software allows you to communicate and share resources with remote OpenVMS systems, UNIX systems, and other systems that support the TCP/IP protocol suite.

The product consists of a number of components that implement various TCP/IP protocols. These components provide remote computing, file transfer, resource sharing, electronic mail, and network services as follows:

Table 1.1. TCP/IP Components

| Remote Computing | |
|------------------|---|
| FINGER | Display information about users logged in to a remote host, such as their login user names or programs they are using. |
| RCP | Copy files between the local host and a remote host or between two remote hosts. Requests are authenticated on the remote host or hosts using the user name supplied by RCP. |
| RLOGIN | Connect to a remote host, which starts an interactive login session. Requests are authenticated on the remote host using the user name supplied by RLOGIN. |
| RMT/RCD | Access magnetic tape and CD drives on a remote host as though they are available locally. |
| RSH | Connect to a remote host, which executes the command you specify. Requests are authenticated on the remote host using the user name supplied to RSH. |
| RSH/PASSWORD | Use the REXEC facility to connect to the remote host, which executes the command you specify. Requests are authenticated on the remote host using the user name and password supplied by RSH. |
| RMT/RCD | Access magnetic tape and CD drives on a remote host as though they are available locally. |
| TELNET | Log in to a remote host in a network using various options to customize the session, control output from the remote host, and negotiate compatibility differences. To start a TELNET session, enter the following command: \$ TELNET |
| File Transfer | |

| | |
|-----------------------|--|
| FTP | Create, delete, and copy files and directories between hosts. To start an FTP session, enter the following command: \$ FTP |
| TFTP | Transfer files using the UDP protocol and no authentication. Typically used during the bootstrap process of diskless systems. |
| Resource Sharing | |
| LPD/LPR | Print files on remote and local hosts. |
| NFS | Authenticate requests and provide access to remote files. |
| TELNETSYM | Print files on remote hosts using the TELNET protocol. |
| Electronic Mail | |
| IMAP | View, move, copy, and delete electronic mail from your PC, and in conjunction with SMTP, create and send mail. |
| POP | Send and receive electronic mail from your PC. |
| SMTP | Send and receive electronic mail from remote hosts. |
| Programming Utilities | |
| MIBCOMP | Compile SNMP subagent source files in ASN.1 format. |
| RPCGEN | Create programming skeletons that implement the RPC mechanism. |
| Network Services | |
| BIND | Name and address resolution service to distribute and manage host information. |
| BOOTP | Answer bootstrap requests from remote devices. |
| DHCP | Configure and maintain your IP address space including the temporary assignment of IP addresses. |
| Management commands | Manage your TCP/IP environment. To start the management control program, enter the following command: \$ TCPIP For online descriptions of the management commands, enter the following command: \$ TCPIP HELP |
| NSLOOKUP | Determine if your local name server is running correctly or retrieve information from remote servers. |
| NTP | Synchronize time between hosts. |

| | |
|-------------|--|
| PPP | Connect a node to a network using IP or other supported network protocols. |
| SLIP, CSLIP | Connect a node to a network over a serial connection using IP. |
| SNMP | Monitor and manage network devices from across an internetwork. |
| TCPDUMP | Analyze dumps and capture packets. |
| TCPTTRACE | Trace packets going in and out of the system. |

Your particular installation may include some or all of the above components. For information about the components available to you, see your system or network manager.

System or network managers are generally authorized to install, configure, and manage the various TCP/IP components on your system. And, as such, many of the TCP/IP components are used primarily by system or network managers and are seldom needed by TCP/IP users. You can find the details of system management components and commands in the *VSI TCP/IP Services for OpenVMS Management* guide and the *VSI TCP/IP Services for OpenVMS Management Command Reference* manual.

If you are a TCP/IP user and want to manipulate files on remote systems, send and receive electronic mail, log in to remote systems, or enter commands remotely, this user guide provides the information and commands you need.

1.1. Which Service Should You Use?

Some of the TCP/IP Services components provide similar capabilities. Table 1.2 helps you determine the best component to use for your specific needs and indicates where to look for information about that component.

Table 1.2. Components to Use for Specific Tasks

| To obtain user information, if you need to... | Use... | Refer to... |
|---|--------|---|
| Get information about users logged in to a remote host, such as their login user names, current program being used, and last login. | FINGER | Section 7.3 |
| Get information about users logged in to your OpenVMS Cluster. | FINGER | Section 7.3 |
| To copy files, if you need to... | Use... | Refer to... |
| Perform other operations on the files, such as deleting, renaming, appending, and viewing files. | FTP | Section 2.9, Section 2.10, Section 2.11 |
| Copy multiple files to or from one or more unrelated directories on the remote host. | FTP | Section 2.3.1, Section 2.6, Section 2.8 |
| Copy every file and subdirectory in a directory on a host, | RCP | Section 3.4 |

| | | |
|--|--------------------|--------------------------|
| preserving the directory hierarchy. | | |
| Create or delete directories, and display the contents of directories. | FTP | Section 2.5, Section 2.7 |
| Copy files between two remote hosts. | RCP | Section 3.8 |
| Perform fast file transfers between two OpenVMS hosts. | FTP | Section 2.8.5 |
| Copy files to and from a remote UNIX system, preserving RMS file attributes. | FTP | Section 2.8.6 |
| Copy files, preserving the protection mode and modification date. | RCP | Section 3.8 |
| Copy and work with files using DECnet file specifications. | FTP | Section 2.15 |
| To print files, if you need to... | Use... | Refer to... |
| Send local files to a remote host printer or print queue, using the OpenVMS printing options such as customizing the printed page with special print forms and specifying the number of copies to print. | DCL PRINT | Section 6.1 |
| Display the status of remote print queue jobs and cancel print jobs in that queue. | LPQ, LPRM | Section 6.2, Section 6.3 |
| Send remote UNIX files to a local print queue. | lpr ^{dag} | Section 6.4 |
| To log in to remote accounts, if you need to... | Use... | Refer to... |
| Log in to a remote host that runs Remote (R) protocols. | RLOGIN | Section 3.5 |
| Log in to a remote host, using many options to customize the session, control output from the remote host, and negotiate compatibility differences. | TELNET | Section 4.10 |
| Establish multiple, simultaneous login connections with one or more hosts, and toggle between the sessions. | TELNET | Section 4.9 |
| Log in using IBM 3270 Information System (IDS) terminal emulation with a host | TN3270 | Section 4.12 |

| | | |
|--|------------------------------|--------------------------|
| that uses IBM 3270 model terminals. | | |
| To enter remote commands, if you need to... | Use... | Refer to... |
| Enter a command on a remote host, including a command that invokes a remote shell script or command procedure, with any output displayed at your terminal. | RSH, REXEC | Section 3.6, Section 3.7 |
| Enter a command, without specifying user authentication information, on a remote host that has authentication files. | RSH | Section 3.6 |
| Enter a command and password to a host that does not have authentication files for you. | RSH/PASSWORD ^{DDAG} | Section 3.7 |
| To send and receive mail, if you need to... | Use... | Refer to... |
| Send mail to, and receive mail from, a remote host using SMTP. | MAIL | Chapter 5 |
| Send and receive OpenVMS mail, at your PC. | MAIL, POP, IMAP | Section 5.12 |

^{dag}This command must be entered at the remote UNIX host. A queue on your local OpenVMS system must be set up by the system manager to receive the UNIX print jobs. The queue must be identifiable by the UNIX system.

^{DDAG}Issuing the /PASSWORD qualifier with the RSH command invokes the REXEC facility, which sends the password to the specified remote host.

1.1.1. Services for Working with Files

FTP allows you to establish a session with a remote host and enter an unlimited number of commands that copy, display, or manipulate files and directories. The Anonymous FTP feature (See Section 2.3.2) allows you to connect to a remote host without specifying user authentication information. If that feature is not enabled, you must supply user authentication information for a remote host only once: when you first establish the FTP connection with a remote host. FTP allows you to determine or change the working directory on your host and on the remote host, and to perform various other operations on files and directories.

In contrast, RCP is limited to copying files. To copy files, each RCP command that you enter establishes a separate link for each file transfer with the specified remote host. With each RCP command, you must specify the remote host to or from which you want to copy files. As with FTP, RCP has a feature that allows you to connect to remote hosts without specifying user authentication information. However, if that feature is not enabled, you must enter user authentication information with each RCP command, rather than just once (as with FTP) for any number of subsequent commands for a connected host.

1.1.2. Services for Remote Logins

The RLOGIN, TELNET, and TN3270 services each allow you to log in to a remote host and enable your terminal to perform as if directly connected to the remote host. Use RLOGIN for simple logins in which you do not require much customization or control of the terminal-to-host interaction. Use

TELNET if you want to use its extensive terminal features and controls, or if you want to open several terminal sessions with one or more remote hosts. TELNET supports a wider variety of terminal features and behaviors between disparate, otherwise incompatible, systems than RLOGIN.

Use TN3270 to connect your terminal to a remote host that supports IBM 3270 IDS terminals. TN3270 assigns IBM 3270 functions to your keyboard and allows you to redefine keys.

1.1.3. Services for Issuing Commands at a Remote Host

The RSH and REXEC services allow you to send any commands supported by the remote host operating system. RSH and REXEC issue one command per link. If user authentication is required, you must enter the authentication information with each command. There is no REXEC command. Rather, you invoke REXEC when you enter the RSH command with a password (RSH/PASSWORD).

Note that RLOGIN, TELNET, and TN3270 allow you to log in to a remote host once and then perform any number of commands supported by the remote host's operating system. TELNET and TN3270 also allow you to send certain commands to the connected remote host during a terminal session. However, these are a limited range of commands dealing with communication between hosts; they are not operating system commands. For example, you can send a command that aborts output or interrupts execution of a command you entered previously.

1.2. Client/Server Software

The user services include client and server software that communicates between host systems. Your local host includes client software that responds to your commands by requesting the appropriate services from the remote host you specify. If the remote host has the appropriate server software, the server on that host responds with the requested service.

For example, Figure 1.1 shows the interaction between the FTP local client and remote server. The FTP client requests the FTP server on `hostb` to open a connection.

Figure 1.1. FTP Client/Server Software Interacting

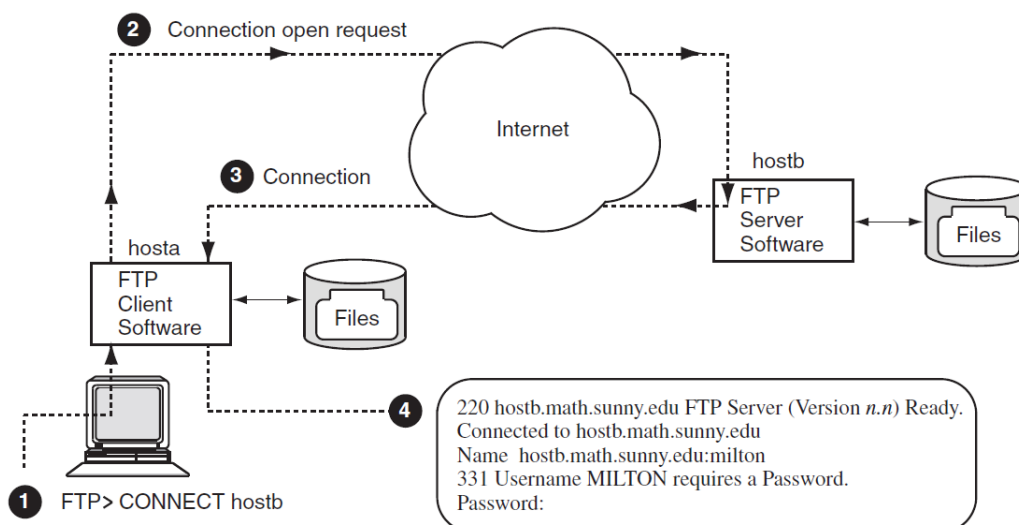

- **1** – User MILTON enters an FTP CONNECT command from local host `hosta` to connect to remote host `hostb`.

- **2** – The FTP local client sends a connection request to the FTP server on `hostb`.
- **3** – The remote server grants the request, sending a data connection status message back to the local client.
- **4** – The client displays at user MILTON's terminal the server connection status message and the remote host prompt for login information.

Once the connection is made, user MILTON can then log in to the remote system and use FTP to copy files and perform other related services. Note that both server and client software exist on each system supporting FTP. Thus, a user on `hostb` could connect to `hosta` and copy files to and from `hostb`.

1.3. User Commands

The FTP, TELNET, and TN3270 components include a wider variety of commands than do the other user services.

You can start FTP, TELNET, or TN3270 and connect to a remote host interactively in either of two ways:

- Specify the component name followed by the Enter key. The component's prompt appears, and you can then enter the `CONNECT` command. For example, to start an FTP session and then connect to a remote host named `FATHM`, type:

```
$ FTP RETURN
FTP> CONNECT FATHM
.
.
.
FTP>
```

- Specify the service name and host name in one line, as in the following example:

```
$ FTP FATHM RETURN
.
.
.
FTP>
```

In either case, you are prompted for user authentication information. (FTP includes a feature that allows you to connect to a remote host without specifying user authentication information (see Section 2.3.2).) You can also start these services by using a command procedure.

Start the Remote (R) and network printer services by specifying the appropriate command, host name, and parameters or qualifiers in one command line. If you specify the service command only (RCP, RSH, RLOGIN, PRINT, LPQ, or LPRM), the service prompts you for the information required for the command. The `PRINT` command supports remote printing using TCP/IP protocols and supporting the `DCL PRINT` qualifiers, with a few exceptions and additional features, as explained in Section 6.1.

When you enter the `FINGER` command without any host or user information, the command displays information about users on your local system. To display information about remote users, you need to specify the remote host name. For more details and options, see Chapter 7.

To start `MAIL` and then send a message to a user on another internet host, simply start OpenVMS Mail as you normally do, and use the `SEND` command with the Internet address of the remote host.

OpenVMS Mail uses the SMTP protocol to send the mail. (See Chapter 5 for details about exceptions and alternatives.) For example:

```
$ MAIL
MAIL> send Return
To: MALCOLM@PHILOS.BU.ORG Return
Subj: FINAL EXAMS Return
.
.
.
FTP>
```

1.4. Command Syntax

Use the following rules when you type a command line:

- OpenVMS and UNIX command syntax

Most command descriptions specify both a DCL syntax and a UNIX syntax. You can, therefore, use command lines in either syntax. For example, the following two command lines achieve the same results:

```
TELNET> CONNECT BENTLEY
TELNET> open bentley
```

- *Keyword abbreviations*

You can abbreviate commands and qualifiers to the fewest number of characters, usually three, that uniquely identifies the keyword. For example, the following two command lines achieve the same results:

```
$ RL RENT /USE=BUNNINGS
$ RLOGIN RENT /USER_NAME=BUNNINGS
```

- *Quotation marks*

Due to differences in OpenVMS and UNIX command syntax, some commands require quotation marks for selected keywords. These requirements apply to case sensitivity, slashes, and certain special characters (such as `&`, `=`, and `\`).

UNIX is case sensitive; UNIX host names, user names, and passwords are usually lowercase. Enclosing them in quotation marks preserves the correct casing. For the requirements for individual services, see the discussions about quotation marks in the following chapters:

- Chapter 2 (FTP)
- Chapter 3 (R commands)
- Chapter 4 (TELNET, TN3270)
- Chapter 5 (electronic mail (SMTP))
- Chapter 6 (network printing)

- *Names and addresses*
-

Unless otherwise stated, whenever you specify a host on a command line, you can use its host name, a fully qualified domain name, or its IP address. The following examples show two ways to enter the TELNET command to connect to host VENDOR at IP address 17.22.3.4.

```
$ TELNET VENDOR
Trying...17.22.3.4
Connected to VENDOR.
Escape character is '^]'.
()
UNIX V5 (vendor.goods.igcorp.com)
login:
```

or

```
$ TELNET 17.22.3.4
Trying...17.22.3.4
Connected to 17.22.3.4.
Escape character is '^]'.
()
UNIX V5 (vendor.goods.igcorp.com)
login:
```

- *File and directory names*

When you specify OpenVMS directory names and file names, follow OpenVMS file specification rules, as explained in the OpenVMS documentation. Likewise, when you specify UNIX directory names and file names, follow UNIX file specification rules, as explained in the documentation supplied with the UNIX system.

- *Multiple values for parameters*

To specify multiple values for command parameters, such as host names and directories, follow these guidelines:

- Separate elements with commas.
- Wildcards are valid.
- A space between multiple elements is optional.

The following FTP GET command copies the files PROJ1.TXT and GROUP1.TXT, using a comma to separate the file names in the command line:

```
FTP> GET PROJ1.TXT, GROUP1.TXT
```

The following FTP GET command uses the asterisk (*) wildcard to copy all files starting with the letters "PROJ1":

```
FTP> GET PROJ1*.*
```

- *Multiple values for qualifiers*

To specify multiple values for qualifiers, enclose them in parentheses as follows:

```
/ qualifier=(value1, value2, value3)
```

For example, the following LPRM command deletes three jobs from a remote print queue:

```
$ LPRM EST_4_1997_Q /ENTRY=(555,556,558)
```

- *Numeric values*

Unless stated otherwise, all values are decimal.

- *Braces and brackets*

Command format descriptions in this manual include elements that are enclosed by braces and brackets. You should understand the meaning of the braces and brackets:

- Braces ({ }) — Indicate that you must specify at least one of the enclosed values. Each element is either listed on a separate line or separated by vertical bars (|). Occasionally, you may need to specify all of the enclosed values (this case is always noted).

Example:

The command SET MODE requires you to specify either CHAR or LINE.

```
SET MODE {CHAR} | {LINE}
```

- Brackets ([]) — Indicate that the enclosed values are optional.

Example 1:

The last two parameters for the TELNET CONNECT command are enclosed in brackets, which means they are optional. In this example, the port can be specified without a terminal type, and the host without a port.

```
CONNECT host [ port [ terminal_type ] ]
```

Example 2:

The format of the RSH command shows that all the qualifiers and the remote_command parameter are optional.

```
RSH host
  [ /EIGHTBIT ]
  [ /ESCAPE_CHARACTER=character ]
  [ /LOG_FILE=file ]
  [ /[NO]LOWERCASE ]
  [ /PASSWORD=password ]
  [ /[NO]SYSERROR ]
  [ /TERMINAL_SPEED=n ]
  [ /TERMINAL_TYPE=type ]
  [ /[NO]TRUNCATE_USER_NAME ]
  [ /USER_NAME=remote_user_name ]
  [ remote_command ]
```

1.5. Online Help

You can access most of the introductory material in this manual on line by entering the following command:

```
$ HELP TCPIP_Services
```

Options under this heading include introductory information about the TCP/IP services.

In addition to this overview information, you can access help on a number of specific TCP/IP commands directly at the DCL prompt. For example:

```
$ HELP FTP
```

Because TELNET, FTP, and the management commands generate their own system prompts, you need to invoke those services first to get help with specific commands, as shown in the following examples:

- FTP

```
$ FTP  
FTP> HELP
```

- TELNET

```
$ TELNET  
TELNET> HELP
```

- Management commands

```
$ TCPIP  
TCPIP> HELP
```

Chapter 2. Working with Files Using the File Transfer Protocol (FTP)

The FTP Protocol allows the transferring of data between hosts that use the same or dissimilar file systems. The FTP command is the interface to the File Transfer Protocol and provides commands that allow you to perform the following actions:

- List remote directories
- Change the current local and remote directory
- Transfer multiple files in a single request
- Create and remove directories
- Provide security by sending passwords to a remote host
- Permit automatic login, file transfer, and log off
- Preserve RMS file attributes

FTP does not allow recursive copying; that is, you cannot copy the contents of directories contained in other directories, such as using the following DCL command:

```
COPY [ . . . ] * .TXT * . *
```

If you need this function, you can use the RCP command.

To use FTP, you need the following:

- A user account on the OpenVMS system with access to TCP/IP Services for OpenVMS
- One of the following:
 - A user account on the remote FTP host
 - Access to the remote host's ANONYMOUS user account (Section 2.3.2)

The following table lists FTP capabilities and the sections that explain how to use them.

| Capability | Section |
|---|----------------|
| Allow use of DCL or UNIX command syntax. | 2.1 |
| Customize the way FTP processes commands and file transfers. | 2.13 2.14.2 |
| Display all FTP commands sent to the remote host during command processing. | 2.13 |
| Display all replies from the remote host during command processing. | 2.13 |

| Capability | Section |
|--|---------|
| Access OpenVMS files without specifying your user name or a password. | 2.3.2 |
| Allow use of either OpenVMS or UNIX command syntax in command procedures that use FTP. | 2.14 |
| Set and display the default (working) directory on the local or remote host. | 2.6 |
| Create and delete remote directories. | 2.7 |
| View remote directories. | 2.5 |
| Delete a remote file. | 2.9 |
| Rename a remote file. | 2.9 |
| Append a local file to a remote file. | 2.11 |
| Display the contents of a file on a remote host. | 2.10 |
| Copy files from a connected remote host to your local host. | 2.8.1 |
| Copy files from your local host to the connected remote host. | 2.8.2 |
| Preserve OpenVMS file attributes when copying files to a UNIX system and back again. | 2.8.6 |
| Copy files to and from a DECnet node. | 2.15 |
| Suspend FTP to spawn a subprocess at the DCL prompt. | 2.12 |

Table 2.1 lists and describes FTP commands. (For complete command descriptions, see Section 2.16).

Table 2.1. FTP Command Summary

| DCL Command | Equivalent UNIX Command | Description |
|---|------------------------------|--|
| Starting and Exiting (at the DCL Prompt) | | |
| FTP | <code>ftp</code> | Invokes FTP. |
| FTP <i>remote_host</i> | <code>ftp remote_host</code> | Invokes FTP and establishes a connection to a remote host. |
| Starting and Exiting (at the FTP> Prompt) | | |
| CONNECT | <code>open</code> | Establishes a connection to a remote host. |
| DISCONNECT | <code>close</code> | Closes the connection with a remote host. |

| DCL Command | Equivalent UNIX Command | Description |
|--|--------------------------------|---|
| EXIT Ctrl/Z | quit or bye | Closes the connection with a remote host and exits FTP. |
| Sending Commands to the Remote Host | | |
| APPEND | append | Concatenates a local file to a remote file. |
| CREATE/DIRECTORY | mkdir | Creates a remote directory. |
| DELETE | delete mdelete | Deletes remote files. |
| DIRECTORY | ls | Lists remote file names and related information. |
| GET | get mget | Copies files from the remote host to the local host. |
| LOGIN | user | Logs you in to a remote host. |
| PUT | put mput | Copies files from the local host to the remote host. |
| RENAME | rename | Changes file names on remote systems. |
| SET DEFAULT SET DEFAULT/LOCAL | cd lcd | Sets the remote working directory or the local working directory. |
| SHOW DEFAULT SHOW DEFAULT/LOCAL | pwdlpwd | Displays the name of the remote current working directory or the local working directory. |
| VIEW | view | Displays the contents of a file on the current output device. |
| Suspending FTP to Return to DCL Prompt | | |
| SPAWN | ! | Suspends FTP to create a subprocess at the local DCL prompt. |
| Customizing Your Session's Environment | | |
| DISABLE LOG | debug ^{dag} | Disables the display of all the protocol commands sent to the remote host. |
| DISABLE PARSE | glob ^{dag} | Disables the expansion of file names. |
| DISABLE PORT_COMMAND | sendport ^{dag} | Disables the sending of the FTP protocol PORT command. |
| DISABLE REPLY | N/A | Disables the display of all responses from the remote host. |

| DCL Command | Equivalent UNIX Command | Description |
|----------------------------------|-------------------------|--|
| DISABLE TRANSFER_VERIFICATION | hash ^{dag} | Disables the display of the pound sign (#) for each 1K bytes of data transferred. |
| DISABLE VMS_PLUS | N/A | Disables the special OpenVMS-to-OpenVMS transfer mode. |
| ENABLE LOG | debug ^{dag} | Enables the display of protocol commands sent to the remote host. |
| ENABLE PARSE | glob ^{dag} | Enables the expansion of file names. |
| ENABLE PORT_COMMAND | sendport ^{dag} | Enables the sending of the FTP protocol PORT command. |
| ENABLE REPLY | N/A | Enables the display of responses from the remote host. |
| ENABLE TRANSFER_VERIFICATION | hash ^{dag} | Enables the display of the pound # sign for each 1K bytes of data transferred. |
| ENABLE VMS_PLUS | N/A | Enables the OpenVMS-to-OpenVMS transfer mode. |
| HELP | ? | Invokes help. |
| QUOTE | quote | Sends FTP commands to the remote host without local interpretation. |
| SET TYPE | type | Defines the data representation for file transfers. |
| SHOW STATUS | status | Displays the current FTP parameter settings and, if you have an open connection, the name of the connected host. |
| SPAWN | ! | Starts a subprocess at the DCL prompt. |

^{dag}This command toggles the value between enabled and disabled.

2.1. Using FTP Commands

Use the following rules for command syntax, quotation marks, and wildcard characters when you type FTP command lines.

2.1.1. DCL and UNIX Command Syntax

With the FTP command and most of the commands at the FTP prompt, you can use either DCL or UNIX command syntax. For example, the DCL DIRECTORY and the UNIX `ls` commands produce the same results, as shown in the following example:

```
FTP> DIRECTORY/BRIEF *.DIR
```

```
200 PORT command successful.
150 Opening data connection for WORK1$:[VANA]*.DIR;* (130.180.4.8,1797)
BIN.DIR;1
MAIL.DIR;1
NEWS.DIR;1
NSLOOKUP.DIR;1
USER.DIR;1
```

```
226 NLST Directory transfer complete
63 bytes received in 00:00:00.02 seconds (2.12 Kbytes/s)
```

```
FTP> ls *.DIR
200 PORT command successful.
150 Opening data connection for WORK1$:[VANA]*.DIR;* (130.180.4.8,1798)
BIN.DIR;1
MAIL.DIR;1
NEWS.DIR;1
NSLOOKUP.DIR;1
USER.DIR;1
```

```
226 NLST Directory transfer complete
63 bytes received in 00:00:00.03 seconds (2.05 Kbytes/s)
```

2.1.2. Quotation Marks

When you communicate with a non-OpenVMS host, you might need to enclose the following within quotation marks:

- UNIX path names
- UNIX file names with slashes
- Lowercase or mixed-case host names, user names, passwords, file names, and command lines

As shown in the following example, enclose UNIX path names with quotation marks:

```
FTP> put MY.DOC "/usr/users/evt/my.doc"
200 PORT command successful.
150 Opening ASCII mode data connection for /usr/users/evt/mydoc
(130.180.4.8,1789).
226 Transfer complete.
local: WORK1$:[VANA]MY.DOC;2 remote: /usr/users/evt/my.doc
289 bytes sent in 00:00:00.01 seconds (20.15 Kbytes/s)
```

2.1.3. Wildcards

You can use wildcards in the following FTP commands: DELETE, DIRECTORY, GET, PUT, MGET, MPUT, MDELETE, and MLS.

The wildcard characters recognized by FTP include the following:

- The percent sign (%) to represent an individual character
- The question mark (?) to represent an individual character
- The asterisk (*) to represent multiple characters

If any of these characters are part of a file name but are not used as a wildcard, you can disable recognition of these characters as wildcards by either enclosing the file name in quotation marks or using the `DISABLE PARSE` command.

2.1.4. Qualifiers

In DCL command lines, you can place a command qualifier anywhere on the command line. It is a good practice to follow the OpenVMS recommendation of placing the qualifier after the command name.

In the following example, all three uses of the `GET` command are correct.

```
FTP> GET TEMP. *.* /CONFIRM           ❶
FTP> GET /CONFIRM TEMP. *.*           ❷
FTP> GET/CONFIRM TEMP. *.*           ❸
Get TEMP. ? [Y or N ] [Y]:Y
200 TYPE set to IMAGE.
200 PORT command successful.
150 Opening data connection for TEMP. (130.180.4.8,2634)
226 Transfer complete.
local: WORK10$:[MILGROM]TEMP.;13  remote: TEMP.
153 bytes received in 00:00:00.01 seconds (9.33 Kbytes/s)
FTP>
```

- ❶ The `/CONFIRM` qualifier follows the file name parameters rather than the `GET` command.
- ❷ The `/CONFIRM` qualifier follows the `GET` command, but with a space between the command and the qualifier.
- ❸ The `/CONFIRM` qualifier immediately follows the `GET` command, with no space between the two. FTP prompts the user to confirm that file `TEMP.` is to be copied and then sends a copy of the file from the remote host.

2.2. Obtaining Online Help

You can obtain online help for the FTP service and FTP commands by typing any of the following commands:

- At the DCL prompt:

```
$ HELP TCPIP_SERVICES FTP
$ HELP FTP
```

- At the FTP prompt:

```
FTP> HELP

FTP>
```

- At the FTP prompt you can type a question mark to get a list of UNIX commands:

```
FTP> ?
```

To obtain information about a specific command, specify the command as shown in the following examples:

- For DCL commands:

```
FTP> HELP APPEND
```

```
APPEND
```

Appends a local file to a remote file. The remote file can reside on any system that supports FTP. To use this command, you must have an FTP session with a remote host.

DCL Syntax

```
APPEND local_file [ remote_file ]
```

UNIX Syntax

```
append local_file [ remote_file ]
```

Additional information available:

| Restrictions | Parameters | Example |
|--------------|------------|---------|
|--------------|------------|---------|

APPEND Subtopic?

- For UNIX commands:

```
FTP> ? append
append          append to a file
```

```
FTP>
```

2.3. Starting FTP Sessions

You can start an FTP session in any of the following ways:

- At the DCL prompt, enter the FTP command and specify a remote host.
- At the DCL prompt, enter the FTP command with no parameters.

At the FTP prompt, enter the CONNECT or open command, specifying a remote host.

- By using the /FTP qualifier on the DCL commands COPY and DIRECTORY.
- Invoke and use FTP from a command procedure (Section 2.14).

You must connect to a remote host before you can enter an FTP command that affects or displays files on the remote host. You can invoke FTP and, without first connecting to a remote host, enter the FTP commands that customize the FTP environment.

2.3.1. Making a Remote Connection

When you establish an FTP connection, the remote user name defaults to your user name on the local system.

If you have a different user name on the remote system, do one of the following:

- On the FTP command line, enter the /USERNAME qualifier.

- At the user name prompt, type your remote user name. For example:

```
$ FTP SITE1

220 sitel.midwest.billing.bench.com FTP server (Version 5.0) ready
Connected to SITE1.midwest.billing.bench.com.
Name (SITE1:antel): crowe Return
331 Username CROWE requires a Password
Password: Return
230 User logged in
```

If your connection is with another OpenVMS host, it executes your LOGIN.COM procedure. You can use your LOGIN.COM command procedure to customize the environment for your FTP sessions.

The following example connects to host XENO using the FTP command:

```
$ FTP XENO /USER="bennings" /PASSWORD="keysimpl"Return
220 xeno FTP Server (UNIX Version 5.60) ready
Connected to XENO.sitel.acctg.com.
230 User logged in
FTP>
```

In the following example, user *dave* invokes FTP and connects to UNIX host *sanfran* using the CONNECT command:

```
$ FTP Return
FTP> CONNECT SANFRAN Return
220 sanfran.golden.com FTP server (UNIX Version 5.60) ready
Connected to sanfran.golden.com.
Name (sanfran:dave): Return
331 Password required for dave
Password: Return
230 User logged in
FTP>
```

2.3.2. Anonymous User Access (Anonymous FTP)

Anonymous user access, also called Anonymous FTP, lets you make an FTP connection to a remote host by specifying the name ANONYMOUS (or another name defined by the system manager). With Anonymous FTP, you do not need:

- A registered user account on the remote host
- To use your own user account, if you have one
- To supply a password

With Anonymous FTP, you can perform the following actions:

- View remote directories
 - View the guest and public directories with the FTP command DIRECTORY.
 - If set up, the public directory called GUEST\$PUBLIC has general bulletin-board information. It contains files of interest to FTP users.
- Copy files

- Enter GET and PUT commands to copy files to and from GUEST\$PUBLIC.
- The public area is read-only. You can enter the GET command to copy files from the remote host to your local system.

Optionally, there may be an ANONYMOUS\$USER directory where you can perform the following actions:

- Delete files
- Create directories
- Delete directories
- Rename files
- Rename directories

The system manager sets up the access restrictions for Anonymous FTP that determine the availability of features.

Note

GUEST\$PUBLIC and ANONYMOUS\$USER are device names for directories that may be set up by the system manager. See the *VSI TCP/IP Services for OpenVMS Management* manual for more information.

In the following example, UNIX user `williams` uses Anonymous FTP to connect to the ANONYMOUS account on OpenVMS host TRACTPLAN. Rather than prompt for a password, TRACTPLAN asks for the user name.

```
% ftp tractplan
Connected to tractplan.green_dev.org.
220 tractplan FTP Server (Version 5.1) ready
Name (tractplan:williams): anonymous
331 Guest login ok, send ident as password
Password: williams@tractplan.edu
230 Guest login ok, access restrictions apply
```

2.4. Exiting FTP

You can end an FTP session and return to the DCL prompt by entering the EXIT, quit, or bye commands or by pressing Ctrl/Z. The following examples close a connection with the remote host and exit FTP.

```
FTP> EXIT
221 Goodbye.
$
```

```
FTP> quit
221 Goodbye.
$
```

To close a connection and remain at the FTP prompt, use the DISCONNECT or close command.

The following examples show how to close a connection, if one is open, and remain at the FTP prompt for you to continue using FTP.

```
FTP> DISCONNECT
221 Goodbye.
FTP>
```

```
FTP> CLOSE
221 Goodbye.
FTP>
```

2.5. Viewing Directories on the Remote Host

Use the DIRECTORY command to list the files and associated information in remote directories. For example, the following command lists the files in the default directory on a remote UNIX host (assuming the user already has connected to the remote host):

```
FTP> DIRECTORY
200 PORT command successful
150 Opening ASCII mode data connection for /bin/ls (130.180.4.8,1312)
total 6303
-rw-rw-r-  1 milgrom  users          1 Jan  9  2002 #UNTITLED#
-rw-----  1 milgrom  users           4 Apr 11  2002 .Xauthority
-rwxr-xr-x  1 milgrom  users        1499 Feb  3  2002 .cshrc
drwxr-xr-x 11 milgrom  users        8192 Jan  9  2002 .dt
-rwxr-xr-x  1 milgrom  users        3970 Dec 13  2002 .dtprofile)
```

2.6. Displaying and Changing the Default Directory

During an FTP session, you can display or change the current default directory either on the remote host or on your local host.

To display the default (working) directory on the remote host, use the SHOW DEFAULT command, as in the following example:

```
FTP> SHOW DEFAULT
257 "/usr/users" is the current directory.
```

To display the working directory on the local host, use the SHOW DEFAULT command with the LOCAL qualifier, as in the following example:

```
FTP> SHOW DEFAULT/LOCAL
Local directory is DISK$6:[MANAGER].
```

To change the default directory on the remote host, use the SET DEFAULT command. The following example shows how to change the default directory on a remote UNIX host to /usr/users/robert:

```
FTP> SET DEFAULT "/usr/users/robert"
250 CWD command successful.
```

or

```
FTP> SET DEFAULT "~robert"
```

To change back to your login default directory, specify a tilde (~) alone, as follows:

```
FTP> SET DEFAULT ~
250 CWD command successful.
FTP> pwd
257 "/usr/users/robert" is current directory.
```

The following example changes the remote working directory from /usr/flyers/localads to /usr/flyers/localads/music:

```
FTP> SET DEFAULT MUSIC
```

To change the default directory on your local host, use the SET DEFAULT command with the /LOCAL qualifier. The following example sets the local default directory to USER\$1:[PLANS.CHECKS]:

```
FTP> SET DEFAULT/LOCAL USER$1:[PLANS.CHECKS]
Local Directory now USER$1:[PLANS.CHECKS]
```

The following example changes the local OpenVMS default directory down one level from [DECK] to [DECK.HEARTS]:

```
FTP> SET DEFAULT/LOCAL [.HEARTS]
```

2.7. Creating and Deleting Directories

To create a directory on a connected remote host, use the CREATE/DIRECTORY command. The following example creates a subdirectory LOCAL_ACCTS in the current working directory on the connected remote OpenVMS host.

```
FTP> CREATE/DIRECTORY [.LOCAL_ACCTS]
```

To delete a directory, use the DELETE/DIRECTORY command as in the following example. The command deletes the directory created in the preceding example.

```
FTP> DELETE/DIRECTORY LOCAL_ACCTS.DIR;*
```

2.8. Copying Files

To copy files from a remote host to your local host, use the GET command. To copy files from your local host to a remote host, use the PUT command. To use these commands, you must have an active FTP session with a remote host. You can enter any number of commands during the session. For information on using these commands to copy files to and from a remote DECnet host, see Section 2.15. You can also use the COPY/FTP command to copy files across the network using TCP/IP. For more information on this command, type HELP COPY/FTP at the DCL prompt.

2.8.1. Using the GET Command to Copy Remote Files to the Local Host

Use the GET command to copy one or more files from a remote host to your local host. For example, the following command copies the UNIX file acct.pay, located in the remote working directory, to your local OpenVMS host:

```
FTP> GET ACCT.PAY
```

Figure 2.1. The GET Command

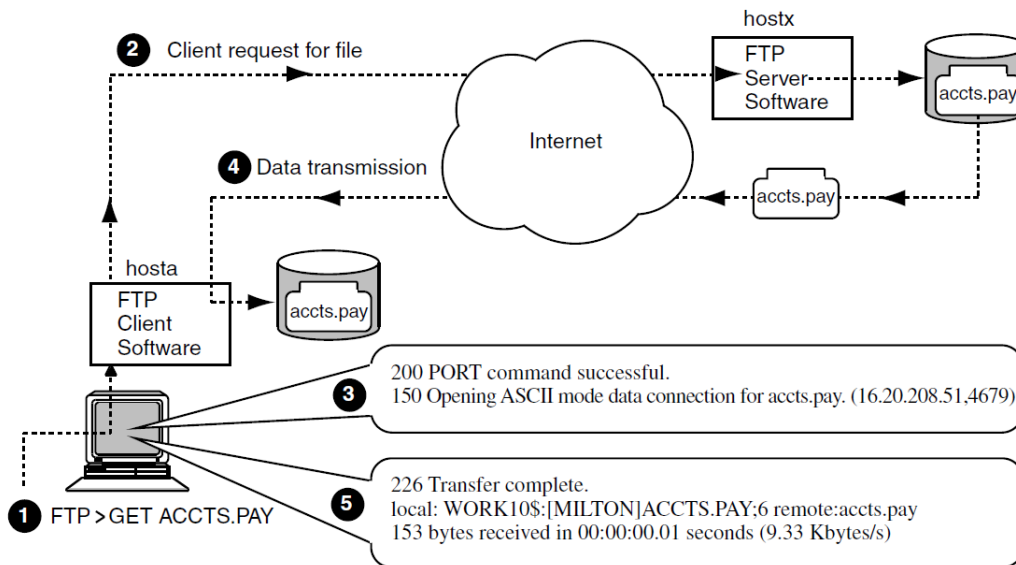

Figure 2.1 shows the following:

- **1** – The user at local host `hosta`, who is connected through FTP to remote UNIX host `hostx`, enters a GET command.
- **2** – The FTP client software on `hosta` sends a request to the remote FTP server on `hostx` to send the requested file.
- **3** – The FTP `PORT` command successful message and the following line indicate the remote server is opening a data connection to send the requested file.
- **4** – The remote FTP server sends the requested file, `acct.pay`, to `hosta`.
- **5** – A message indicates the file transfer was complete and provides additional information about the transfer.

For more information about the GET command, see Section 2.16.

2.8.2. Using the PUT Command to Copy Local Files to the Remote Host

Use the PUT command to copy one or more files from your local host to a remote host. For example, the following command copies the local file `ACCTS.LIS` to a connected remote UNIX host:

```
FTP> PUT ACCTS.LIS
```

To prevent record attributes from being lost in the transfer from an OpenVMS to a UNIX system, use the `/FDL` qualifier to the PUT command. For more information about the `/FDL` qualifier, see Section 2.8.6.

Figure 2.2. The PUT Command

Figure 2.2 shows the following:

- ❶ – The user at local host *hosta*, who is connected through FTP to remote UNIX host *hostx*, enters a PUT command.
- ❷ – The FTP client software on *hosta* requests the FTP server on *hostx* to receive the specified file (*accts.lis*).
- ❸ – The remote FTP server establishes a data connection with the local host.
- ❹ – The PORT command successful message and the following line indicate the remote server will receive the file.
- ❺ – The client sends the requested file, *accts.lis*, to *hostx*.
- ❻ – A message indicates the file transfer is complete and provides additional information about the transfer.

For more information about the PUT command, see Section 2.16.

2.8.3. How FTP Copies Files

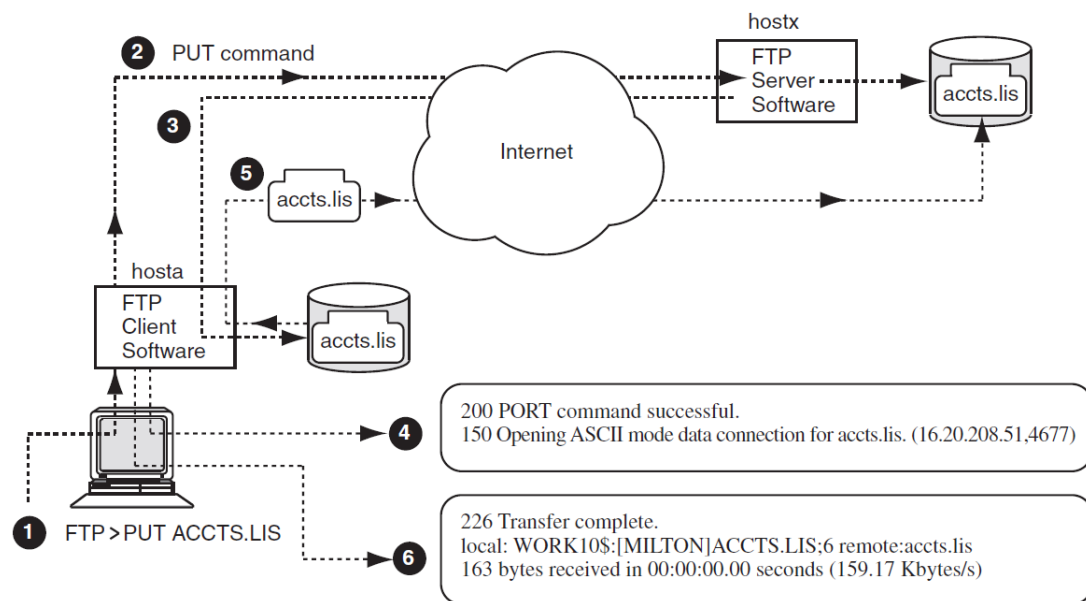
FTP resolves the differences between UNIX file systems and OpenVMS file systems automatically. By default, the PUT command copies files to UNIX systems using lowercase file names without version numbers. If you use a wildcard to copy all versions of a file and do not specify an output file, the following occurs:

- The version numbers become the last element of the copied files.
- Semicolons are converted to periods.

2.8.4. Using the Store Unique Feature

The Store Unique (STOU) feature allows you to control how file version numbers are treated when you copy (PUT) files from local to remote hosts. After connecting to the remote host, you toggle the Store Unique feature on and off by issuing the `sunique` command at the FTP prompt, as follows:

```
FTP> sunique
Store unique on.
FTP> sunique
Store unique off.
FTP> sunique
Store unique on.
```

The Store Unique feature behaves differently when copying files between OpenVMS and UNIX. It also behaves differently if you use wildcards or specify version numbers.

The following table shows the results when you copy the file `text.txt` from OpenVMS to UNIX.

| FTP Command | File <code>text.txt</code> Exists on UNIX System | Store Unique On | Store Unique Off |
|-----------------------------------|--|-------------------------|-----------------------|
| FTP> PUT <code>text.txt</code> | No | <code>text.txt</code> | <code>text.txt</code> |
| FTP> PUT <code>text.txt</code> | Yes | <code>text.txt.1</code> | <code>text.txt</code> |

The next table shows the results when you copy the file `text.txt;*` from OpenVMS to UNIX.

| FTP Command | Files <code>text.txt.1</code> <code>text.txt.2</code> Exist on UNIX System | Store Unique On | Store Unique Off |
|-------------------------------------|---|--|--|
| FTP> PUT <code>text.txt;*</code> | No | <code>text.txt.2</code> <code>text.txt.1</code> | <code>text.txt.2</code> <code>text.txt.1</code> |
| FTP> PUT <code>text.txt;*</code> | Yes | <code>text.txt.2.1</code> <code>text.txt.1.1</code> | <code>text.txt.2</code> <code>text.txt.1</code> |

2.8.5. Transferring Files Between OpenVMS Hosts: VMS Plus Mode

FTP performs fast file transfers between two OpenVMS systems by using VMS Plus Mode.

When FTP identifies file transfers between two OpenVMS hosts running TCP/IP Services, it transfers files in large blocks rather than in small records. VMS Plus Mode greatly increases the transfer speed and preserves all Record Management Services (RMS) file attributes.

FTP automatically disables VMS Plus Mode when your session is with a UNIX host or with an OpenVMS host not running TCP/IP Services.

2.8.6. Preserving OpenVMS File Attributes

When you transfer OpenVMS files to a UNIX system and back again, some record attributes might be lost. To preserve all RMS file attributes, use the `/FDL` qualifier (File Definition Language) with the GET and PUT commands.

You might also need to use the SET TYPE command to determine the type of file transfer:

- Specifying SET TYPE ASCII results in a sequential file with variable records. Select this type when transferring ASCII text files.
- Specifying SET TYPE IMAGE results in a sequential file with fixed records of 512 bytes. Select this type when transferring non-ASCII files, such as binary files or executable image files.

For example, to transfer an executable image to a remote UNIX host, follow these steps:

1. Specify the IMAGE data type:

```
FTP> SET TYPE IMAGE
```

2. Transfer the file to the remote host. At the same time, create and transfer a secondary file with the file's OpenVMS record attributes:

```
FTP> PUT/FDL file
```

To retrieve the file from a remote UNIX host, follow these steps:

1. Specify the IMAGE data type:

```
FTP> SET TYPE IMAGE
```

2. Retrieve the file from the remote host after retrieving and using the secondary file containing the file's OpenVMS record attributes:

```
FTP> GET/FDL file.dat
```

In the following example, the PUT/FDL command does the following:

- Creates the FDL file `cygnet.bckfdl` on the remote host with the RMS attributes of file `STAT.BCK`.
- Transfers the data in `STAT.BCK` and puts it in to `cygnet.bckfdl` on the remote host.

```
FTP> PUT/FDL STAT.BCK CYGNET.BCK
200 TYPE set to ASCII
200 PORT command successful
150 Opening data connection for cygnet.bckfdl (130.180.4.8,1028)
226 Transfer complete
local: cygnet.bckfdl remote: cygnet.bckfdl
846 bytes sent in 00:00:00.03 seconds
200 TYPE set to IMAGE
200 PORT command successful
150 Opening data connection for cygnet.bck (130.180.4.8,1029)
226 Transfer complete
local: STAT.BCK remote: cygnet.bck
8152 bytes sent in 00:00:00.12 seconds
```

In the following example, the GET/FDL command performs the following actions:

- Transfers the FDL file `cygnet.bckfdl` from the remote host to the local host.
- Uses this file to re-create the file `STAT.BCK`, with all of its original RMS attributes, on the local host.
- Transfers the data in `cygnet.bck` to the new local file `STAT.BCK`.

```
FTP> GET/FDL CYGNET.BCK STAT.BCK
200 TYPE set to ASCII
200 PORT command successful
150 Opening data connection for cygnet.bckfdl (130.180.4.8,1028)
226 Transfer complete
local: cygnet.bckfdl remote: cygnet.bckfdl
846 bytes sent in 00:00:00.03 seconds
200 TYPE set to IMAGE
200 PORT command successful
150 Opening data connection for cygnet.bck (130.180.4.8,1029)
226 Transfer complete
local: STAT.BCK remote: cygnet.bck
8152 bytes sent in 00:00:00.12 seconds
```

2.8.7. Transfer Mode

TCP/IP Services supports only STREAM mode for data transfer. STREAM mode transmits the data as a stream of bytes.

2.8.8. File Structure

TCP/IP Services supports transfers of ASCII (stream, records with variable length) and IMAGE (binary, records fixed at 512 bytes) files.

2.9. Renaming and Deleting Files

To change the name of a remote file, use the FTP command RENAME. The following command renames file YEAR.DAT to YEAR96.DAT on the connected remote host:

```
FTP> RENAME YEAR.DAT YEAR96.DAT
```

To remove a remote file, use the FTP command DELETE. The following command deletes all versions of file YEAR.DAT on the connected remote VMS host:

```
FTP> DELETE YEAR.DAT;*
```

2.10. Viewing the Contents of a File

To display the contents of a file on a connected remote host, use the FTP command VIEW and specify the file name. If the file is not in your current working directory, include the directory name in the file specification.

The following example shows how to display the contents of file ENG.DIS located in the remote working directory:

```
FTP> VIEW/PAGE ENG.DIS
usrm::"khuna@jnet.com"
pobox::bearse
yield::timms
usrm::"lerry@muster.cudenver.edu"
sam
nm%uslrnc::"ldutton@TopCom.com"
```

2.11. Appending Files

The FTP command APPEND allows you to concatenate a local file to a file on a connected remote host. The following command appends local file JUL_DEC.DAT to file YEAR.DAT on the connected remote host KALI.

```
FTP> APPEND JUL_DEC.DAT YEAR.DAT
200 PORT command successful
150 Opening data connection for year.dat. (130.180.4.8,1108)
226 Append transfer complete
local:large.txt  remote:remote.dat
15596 bytes sent in 00:00:00.10 seconds (152.30 Kbytes/s)
```

2.12. Suspending FTP to Return to the Local DCL Prompt

While using FTP, you can do the following:

- Use the SPAWN command to suspend your current session and create a subprocess at the local DCL prompt. At the DCL prompt, you can then enter any number of DCL commands. To return to your suspended FTP session (exiting the DCL subprocess), enter the LOGOUT command, as shown in the following example:

```
FTP> SPAWN
$ DIRECTORY

Directory WORK1$:[VANA.FTP]

TELNETINIT.INI;2      TELNETINIT.INI;1

Total of 2 files.
$ SHOW TIME
2-OCT-2002 13:16:32
$ LOGOUT
Process VANA_1 logged out at 2-OCT-2002 13:16:48.26
FTP>
```

- Specify a DCL command in the SPAWN command line. After the DCL command is executed, FTP prompts for further input, as shown in the following example:

```
FTP> SPAWN DIR

Directory WORK1$:[VANA.FTP]

TELNETINIT.INI;2      TELNETINIT.INI;1

Total of 2 files.

FTP>
```

- Use the exclamation point (!) character to spawn a new process to execute a command, as shown in the following example:

```

FTP> ! DIR

Directory WORK1$:[VANA.FTP]

TELNETINIT.INI;2      TELNETINIT.INI;1

Total of 2 files.
FTP>

```

2.13. Customizing FTP Command Processing

You can modify the way FTP transfers files, depending on the following criteria:

- The operating system of the remote host
- The applications you use
- Whether you want wildcard name expansion
- The information you want displayed during processing

The following are a few of the FTP commands that control FTP command processing:

- **ENABLE/DISABLE LOG**
Enables or disables the display of FTP commands sent to the remote host.
- **ENABLE/DISABLE PARSE**
Enables or disables the expansion of file name specifications.
- **ENABLE/DISABLE REPLY**
Enables or disables the display of all responses from the remote host.
- **QUOTE**
Sends FTP commands directly to the remote host without local interpretation.

The preceding commands control the way FTP displays command processing information and status. The **SHOW STATUS** command displays the current status of the FTP client (your local host) and, if you have a connection, of the remote host.

By default, FTP returns multiple lines of error messages (**MULTILINE** is enabled). The first line explains the general problem, while subsequent lines provide details to help you diagnose the source of the problem. These lines may include operating system as well as FTP messages. Applications that use FTP to transfer files under program control often do not need the extra messages returned. To disable the **MULTILINE** feature, when you supply a password to connect to a remote host, precede the password with a hyphen (*- password*), as in the following example:

```
$ FTP /USER=SALINGER /PASSWORD=-LETMEIN HAGELS
```

Use the FTP command **SHOW STATUS** to determine whether the **MULTILINE** feature is enabled.

You can modify the way FTP reacts to errors by using the **SET ERROR_LEVEL** command. By default, the error level setting is **SUCCESS**, which means that when FTP is running in batch mode, a

warning or error message will cause FTP to exit. (FTP runs in batch mode when FTP commands are executed by a command procedure rather than interactively.) If you do not want FTP to exit upon a warning or error message, you can set the error level to ERROR.

For example, in the following command, if the default error level (SUCCESS) is in effect and directory [MILLER.USERS] does not exist, the resulting error would cause FTP to exit.

```
$ FTP CONNECT HAGELS
cd [MILLER.USERS]
DEL *.*;*
EXIT
$
```

If the error level had been set to ERROR, FTP would not exit, and the DELETE command in the command procedure would delete all files in your current working directory. Note that you can also set the error level to WARNING, which causes FTP to tolerate warning messages (but not error messages).

2.14. Command Procedures

You can use either OpenVMS or UNIX command syntax in DCL command procedures that use FTP. You can use command procedures to invoke FTP tasks, connecting to a remote host and performing assorted file operations with the remote host (see Section 2.14.1). You can also use command procedures to customize the FTP environment (see Section 2.14.2).

2.14.1. Task Command Files

You can create DCL command procedures that include FTP commands. In the following example, DCL command procedure FTP_TO_SANFRAN.COM invokes FTP and copies file `needs.lis` from host dave:

```
$! FTP_TO_SANFRAN.COM
$! This command procedure uses FTP from within
$! a DCL command file. Note that the password "letmein"
$! does not need quotation marks, but it is case sensitive.
$!
$ FTP
CONNECT sanfran
LOGIN dave
letmein
GET "nest.lis"
EXIT
$ EXIT
$
```

In the following example, command procedure FTP_PASS_PARAMETER.COM accepts parameters and writes and executes a temporary command procedure.

```
$!
$! FTP_PASS_PARAMETER.COM
$! This method is useful for automated BATCH queue jobs.
$!
$ WS == "WRITE SYS$OUTPUT"
$ IF P1 .EQS "" .OR. P2 .EQS. "" .OR. P3 .EQS. "" .OR. P4 .EQS. ""
$ THEN
$ WS "@FTP_PASS_PARAMETER LOCAL-FILE SYSTEM USERNAME PASSWORD"
```

```

$ EXIT
$ ENDIF
$!
$ COM == "FTP_TEMP.COM"
$ LOG == "FTP_TEMP_COM.LOG"
$ FILE == "'P1'"
$ USER == F$EDIT("'P3'", "LOWERCASE")
$ PASSW == F$EDIT("'P4'", "LOWERCASE")
$!
$ ON WARNING THEN GOTO ERR
$ OPEN/WRITE OUTFILE 'COM
$ WRITE OUTFILE "$ DEFINE SYS$OUTPUT 'LOG'"
$ WRITE OUTFILE "$ FTP"
$ WRITE OUTFILE "open 'P2'"
$ WRITE OUTFILE "user 'USER'"
$ WRITE OUTFILE "'PASSW'"
$ WRITE OUTFILE "put 'FILE'"
$ WRITE OUTFILE "quit"
$ WRITE OUTFILE "$ EXIT"
$ CLOSE OUTFILE
$ @'COM
$ DELETE 'COM;*
$ PURGE 'LOG
$!
$! You can open the FTP_TEMP_COM.LOG file to check for errors,
$! for example, checking the initial return code for
$! 4xx (retry condition), or 5xx (failure condition).
$!
$ EXIT
$!
$ ERR:
$ IF F$TRNLNM("OUTFILE") .NES. "" THEN CLOSE OUTFILE

$ EXIT
$

```

2.14.2. Initialization Command File

Initialization command files can customize your FTP sessions with the SET, ENABLE, and DISABLE commands. These command files are optional. They eliminate the need to enter individual FTP commands, and they run automatically when you invoke FTP.

Initialization command files have the following characteristics:

- Contain only OpenVMS commands.
- Contain only one command per line.
- Are generally named SYS\$LOGIN:FTPINIT.INI.

FTP uses the following search method to locate an initialization file:

1. FTP searches for a file specified by the logical TCPIP\$FTPINIT.
2. If not found, FTP then searches for SYS\$LOGIN:TCPIP\$FTPINIT.INI.
3. If not found, FTP then searches for the file specified by the logical FTPINIT (provided for backward compatibility).

4. If not found, FTP then searches for SYSS\$LOGIN:FTPINIT.INI (provided for backward compatibility).

The following example shows an FTP initialization command procedure.

```
! This file, FTPINIT.INI, sets my FTP parameters
! the way I like them.
!
ENABLE REPLY
ENABLE TRANSFER_VERIFICATION
SET DEFAULT/LOCAL [MILLER.WORK]
```

When you invoke FTP, the initialization file generates output such as the following, which displays environment status:

```
$ FTP
Reply on.
Verbose mode on.
Bell off.
Hash mark printing on (1024/hash mark).
Local directory now SYSS$LOGIN_DEVICE:[MILLER.WORK]
```

2.14.3. Setting Error Level

When you use FTP interactively, *you* decide what actions to take when an error or warning is generated. In batch mode, however, any error message other than SUCCESS causes the batch process to exit by default.

The command procedure in the following example calls a file that does not exist, which generates an error and causes the procedure to exit:

```
$ @TEST_FTP
220 rainbw FTP Server (Version 5.60) ready.
Connected to rainbw.tcp.klg.dec.com.
331 Username PETERS requires a Password
230 User logged in.
200 TYPE set to IMAGE.
200 PORT command successful.
550-Failed to open WORK7$:[PETERS]TMP101.TMP; for input.
550 file not found
221 Goodbye.
```

Internally, the 3-digit FTP protocol reply codes that appear in the preceding output are converted to one of the following OpenVMS system messages:

| FTP Protocol Reply Code | OpenVMS System Message | Explanation |
|-------------------------|------------------------|-------------|
| 1 xx | %TCPIP-S-FTP_PRELIM | Success |
| 2 xx | %TCPIP-S-FTP_COMPLETE | Success |
| 3 xx | %TCPIP-S-FTP_CONTINUE | Success |
| 4 xx | %TCPIP-W-FTP_TRANSIENT | Warning |
| 5 xx | %TCPIP-E-FTP_ERROR | Error |

When a command is executed, FTP checks the return status. In batch mode, the value of the error level determines whether FTP continues with each of the reply codes.

To change the error level, enter the following command, where *x* is SUCCESS, WARNING, or ERROR:

```
FTP> SET ERROR_LEVEL x
```

- If *x* is SUCCESS, then WARNING, ERROR, and FATAL cause FTP to exit.
- If *x* is WARNING, then ERROR and FATAL cause FTP to exit.
- If *x* is ERROR, then only FATAL causes FTP to exit.

Fatal errors always cause FTP to exit.

2.15. Using FTP with DECnet

To copy files to and from a DECnet node, use the standard GET and PUT commands as described in the following paragraphs.

You can copy files to and from DECnet nodes and get remote directory information, if your host and the DECnet node are connected through a host running TCP/IP Services for OpenVMS. Use the full file specification, including the node, device, directory, and file name.

The following PUT command copies local file FAX.TXT to DECnet node CURTAIL and renames the file to CURRENT.TXT:

```
FTP> PUT FAX.TXT CURTAIL::DISK$3:[GEARY.KEEPS]CURRENT.TXT
```

The following GET command copies remote OpenVMS file HOUSING.TXT from DECnet node HABTAT and renames the file to HOUSE.TXT:

```
FTP> GET HABTAT::DISK$2:[NATL.UTAH.SWEST]HOUSING.TXT HOUSE.TXT
```

2.16. Command Descriptions

To start FTP, enter the FTP command at the DCL prompt.

To use FTP commands, type them at the FTP> prompt.

This section provides complete descriptions of each FTP command. The commands are listed alphabetically. The related ENABLE and DISABLE commands are presented together (see the description for ENABLE).

FTP Command Reference

APPEND

APPEND — Appends a local file to a remote file. The remote file can reside on any system that supports FTP. To use this command, you must have an FTP session with a remote host.

DCL Syntax

```
APPEND local_file [ remote_file ]
```

UNIX Syntax

`append local_file [remote_file]`

Restrictions

No wildcards.

Parameters

local_file

Required.

Name of the local OpenVMS file.

remote_file

Optional.

Name of the remote file (either UNIX or OpenVMS).

Example

```
FTP> APPEND LARGE.TXT CHRONOS
```

```
200 PORT command successful.
150 Opening ASCII mode data connection for CHRONOS. (130.180.4.8,1108)
226 Transfer complete
local:work1:[samson]large.txt remote:CHRONOS
15596 bytes sent in 00:00:00.10 seconds (152.30 Kbytes/s)
```

Appends local file LARGE.TXT to UNIX file chronos.

CONNECT

CONNECT — Establishes an FTP connection to a remote host. The remote host can be any operating system that supports FTP.

DCL Syntax

`CONNECT remote_host [port]`

UNIX Syntax

`open remote_host [port]`

Parameters

remote_host

Required.

Remote host to which you want to connect.

port

Optional. Default: 21.

FTP port on the remote host.

Example

```
FTP> CONNECT RETAIL Return
```

```
220 retail.good_co.com FTP Server (Tru64 UNIX Version 5.1) ready.  
Connected to retail.  
Name (retail:dave): Return
```

```
331 Password required for dave  
Password: Return
```

```
230 User dave logged in.  
FTP>
```

Connects user dave to UNIX host retail.

CREATE/DIRECTORY

CREATE/DIRECTORY — Creates a directory on the remote host. The remote directory can be on any operating system that supports FTP. To use this command, you must have an FTP session with a remote host.

DCL Syntax

```
CREATE/DIRECTORY remote_directory
```

UNIX Syntax

```
mkdir remote/path
```

Parameter

remote_directory

remote_path

Required.

Name for the created directory.

Qualifier

/DIRECTORY

The /DIRECTORY qualifier must immediately follow the CREATE command without a preceding space.

Creates a new directory or subdirectory. Must have write access to the lowest-level directory under which the new directory is to be created.

Examples

1. FTP> **CREATE/DIRECTORY TERM**

257 MKD command successful.

In this example:

- The remote host is UNIX.
- The working directory is `/usr/staff/dir`.
- The command creates directory `/usr/staff/dir/term`.

2. FTP> **CREATE/DIRECTORY [.TRANSFERS]**

257 MKD command successful.

In this example:

- The remote host is OpenVMS.
- The working directory is `DUA2:[CENTRAL]`.
- The command creates the OpenVMS directory `DUA2:[CENTRAL.TRANSFERS]`.

DELETE

DELETE — Deletes either UNIX or OpenVMS remote files. To use this command, you must have an FTP session with a remote host. Use caution with the `mdelete` command. The FTP command **DIRECTORY** does not list hidden files (files that start with a period). Using the `mdelete` command with any wildcard deletes hidden files, which you might need.

DCL Syntax

DELETE *remote_file*

DELETE/DIRECTORY *remote_directory*

UNIX Syntax

delete *remote_file*

mdelete *remote_files*

rmdir *remote_directory*

Parameter

remote_file

remote_files

remote_directory

Required.

File, files, or directory to delete.

Qualifier

/DIRECTORY

Optional. The /DIRECTORY qualifier must follow immediately after the DELETE command without a preceding space.

Deletes an empty directory. To delete a directory that is not empty, you must first delete the contents of the directory.

Examples

1. FTP> **DELETE [MAIN.BRANCH]*.*;***

250 DELE of [MAIN.BRANCH]*.*;* successful.

Deletes all files in the remote OpenVMS directory [MAIN.BRANCH].

2. FTP> **DELETE/DIRECTORY BRANCH.DIR;1**

250 RMD command successful.

Deletes the directory [MAIN.BRANCH].

3. FTP> **DELETE "/users/venture/carton"**

250 DELE command successful.

Deletes UNIX file with path name /users/venture/carton.

4. FTP> **mdelete /bids/west/january97/c***

250 DELE command successful.

250 DELE command successful.

250 DELE command successful.

Deletes three UNIX files starting with the letter "c" from directory /bids/west/january97. Note that the messages generated depend on the server. For example, for an OpenVMS server, messages would specify the names of the files deleted.

DIRECTORY

DIRECTORY — Lists the names of remote files and other information about them. The remote files can be on any FTP server. To use this command, you must have an FTP session with a remote host. The DCL DIRECTORY command supports the redirecting of output to a file.

DCL Syntax

DIRECTORY [/BRIEF | /OUTPUT= *output_file*] [*remote_directory*]

UNIX Syntax

ls [*/remote/path*]

mls [*/remote/path*]

Parameter

remote_directory

/remote/path

Optional. Default: default directory.

Directory with the file names you want to list. Wildcards and multiple directories are valid.

Qualifiers

/BRIEF

Optional. Default: full display.

Produces output similar to the UNIX `ls` command.

/OUTPUT= *output_file*

Optional. If you do not specify the **/OUTPUT** qualifier, FTP displays output to `SYSS$OUTPUT`. If you do specify the **/OUTPUT** qualifier, you must supply a valid *output_file* specification.

Name of the file to hold the output.

Examples

1. FTP> **DIRECTORY**

```
200 PORT command successful

150 Opening data connection for /bin/ls (130.180.9.8,1150)

total 76

-rwxr-x-x  1  geary    users  261 Nov  6  2002  .cshrc
-rw-r-r-   1  root     users  128 May 21  11:16  .mailrc
-rwxr-x-x  1  geary    users  182 Nov  6  2002  .profile
drwxr-x-x  2  geary    users  512 Nov  6  2002  bin
.
.
.
```

226 Transfer complete.

911 bytes received in 00:00:00.07 seconds

Displays a full listing of file names in the current default UNIX directory.

```
2. FTP> ls disk3$:[banks.branch.bills]

200 PORT command successful

150 Opening data connection for DISK3$:[BANKS.BRANCH.BILLS]
(11.1.2.3.4)

LOCAL_ACCTS.DIS;1

GO_FIGURE.EXE;14

COMPARE.EXE;4

SUMTOTAL.COM;1

226 NLST Directory transfer complete.

428 bytes received in 00:00:00.41 seconds (10.06 Kbyte/s)

FTP>
```

Displays a listing of file names in the directory of the connected host, which is another OpenVMS system.

DISCONNECT

DISCONNECT — Terminates your session with the remote host and returns to the FTP prompt.

DCL Syntax

DISCONNECT

UNIX Syntax

close

disconnect

Example

```
FTP> DISCONNECT
```

```
221 Goodbye.
```

Disconnects the user from an OpenVMS system.

ENABLE (DISABLE) LOG

ENABLE (DISABLE) LOG — Enables or disables the display of all protocol commands sent to the remote host. Default: DISABLE LOG.

DCL Syntax

ENABLE LOG

DISABLE LOG

UNIX Syntax

debug

Example

```
FTP> ENABLE LOG
Bell off.
Debugging on (debug=1).
FTP> ENABLE REPLY
Reply on.
Verbose mode on.
FTP> PUT PRICES.TXT YEAR.PRICES
-> PORT 1,2,3,4,7,138
200 PORT command successful.
-> STOR PRICES.TXT
150 Opening ASCII mode data connection for small.txt (1,2,3,4,7,138).
226 Transfer complete.
local: WORK1$:[samson]prices.txt;1 remote: year.prices
609 bytes sent in 00:00:00.02 seconds (179.36 Kbytes/s)
FTP> GET LAKE.IBIS LAKE_IBIS.DAT
-> PORT 1,2,3,4,7,138
200 PORT command successful
-> RETR lake.ibis
150 Opening ASCII mode data connection for lake.ibis (1.2.3.4,193)
226 Transfer complete
local: LAKE_IBIS.DAT remote:lake.ibis
4 bytes received in 00:00:00.03 seconds (0.13 Kbytes/s)
FTP>
```

Turns on the display of commands sent to the remote host. Shows all the commands sent to the remote host during the execution of PUT and GET.

ENABLE (DISABLE) PARSE

ENABLE (DISABLE) PARSE — Enables or disables the expansion of remote file names during file transfers. PUT operations: expansion is done by the local host. GET operations: expansion is done on the remote host. During GET operations, an expansion of a directory name might be different from the expansion of other file names. The result depends on the operating systems of the remote and local hosts.

DCL Syntax

ENABLE PARSE

DISABLE PARSE

UNIX Syntax

glob

Example

```
1. FTP> ENABLE PARSE
```

```
FTP> PUT BIRDS*.TXT
```

Enables parsing and the expansion of wildcards. Copies all local files starting with the characters BIRDS and ending with .TXT to the remote host.

```
2. FTP> ENABLE PARSE
FTP> GET *.DOC
```

Because parsing is enabled, the remote host expands the wildcard. All remote files ending in .DOC are copied to the local system.

The command is equivalent to the following:

```
FTP> ENABLE PARSE
FTP> MGET *.DOC
```

ENABLE (DISABLE) PORT_COMMAND

ENABLE (DISABLE) PORT_COMMAND — Enables or disables the sending of the FTP protocol PORT command to the remote host. By default, FTP sends a PORT command when establishing a connection. If this command fails, FTP uses the default data port (20). Disable the sending of the PORT command when you communicate with remote hosts that ignore PORT commands. Default: ENABLE PORT_COMMAND.

DCL Syntax

```
ENABLE PORT_COMMAND
```

```
DISABLE PORT_COMMAND
```

UNIX Syntax

```
sendport
```

Example

```
FTP> ENABLE PORT_COMMAND
FTP> PUT CODE.TXT
200 PORT command successful
150 Opening data connection for CODE.TXT (130.180.10.8,1182)
226 Transfer complete
local: DISK$PROJECT6:[MANAGEMENT]CODE.TXT;9 remote: CODE.TXT
3634 bytes sent in 00:00:00.04 seconds (88.72 Kbytes/s)
```

FTP enters a PORT command before the file transfer.

ENABLE (DISABLE) REPLY

ENABLE (DISABLE) REPLY — Enables or disables the display of all responses from the remote host. Default: ENABLE REPLY.

DCL Syntax

```
ENABLE REPLY
```

DISABLE REPLY

UNIX Syntax

debug

Examples

```
1. FTP> ENABLE REPLY
Reply on.
Verbose mode on.
FTP> get birds.txt dogs.txt
200 PORT command successful.
150 Opening ASCII mode data connection for birds.txt
(130,180,10,8,1570)
(2405 bytes).
226 Transfer complete.
local: WORK1$:[SAMSON]DOGS.TXT;1 remote: birds.txt
2405 bytes received in 00:00:00.03 seconds (60.22 Kbytes/s)
FTP>
```

Enables the display of all the responses from the remote host. Copies `birds.txt` from the remote host to the local file `dogs.txt`, and shows all the executed FTP commands in progress.

```
2. FTP> DISABLE REPLY
Bell off.
Reply off.
Verbose off.
FTP> get birds.txt dogs.txt
FTP>
```

Disables the display of all the responses from the remote host. Copies `birds.txt` from the remote host.

ENABLE (DISABLE) TRANSFER_VERIFICATION

ENABLE (DISABLE) TRANSFER_VERIFICATION — Enables or disables the display of # for each 1000 bytes of transferred data. Default: DISABLE TRANSFER_VERIFICATION.

DCL Syntax

ENABLE TRANSFER_VERIFICATION

DISABLE TRANSFER_VERIFICATION

UNIX Syntax

hash

Example

```
FTP> ENABLE TRANSFER_VERIFICATION
Bell off.
Hash mark printing on (1024/hash mark).
FTP> GET FUTURES.DIS FUTURES_H2.DIS
200 PORT command successful
```

```
150 Opening data connection for futures.dis (11.20.99.100,26)
#####
226 Transfer complete.
local: FUTURES_H2.DIS remote: futures.dis
15596 bytes received in 00:00:00.11 seconds (138.45 Kbytes/s)
FTP>
```

Enables the display of # for each 1000 bytes of transferred data. Copies `futures.dis` to `FUTURES_H2.DIS`, showing when 1000 bytes are transferred.

ENABLE (DISABLE) VMS_PLUS

`ENABLE (DISABLE) VMS_PLUS` — Enables or disables VMS Plus Mode. This lets you specify a transfer mode based on file type (for example, ASCII or image).

Additional Information

With VMS Plus Mode disabled, FTP does not send the FTP command `SITE`. (Older implementations of the FTP server do not support this command.) The FTP client uses the `SITE` command to identify itself (its `SITE` type) to the remote host. The `SITE` type of an FTP client can be one of the following:

- `+VMS+` — The client is in VMS Plus mode.
- `NONE` — The client is not in VMS Plus mode.

Defaults:

- When you use FTP to connect to an OpenVMS host running TCP/IP Services, VMS Plus Mode is enabled.
- When you use FTP to connect to a non-OpenVMS host or to an Open VMS system running software that does not recognize VMS Plus Mode, VMS Plus Mode is disabled.

DCL Syntax

`ENABLE VMS_PLUS`

`DISABLE VMS_PLUS`

UNIX Syntax

There is no UNIX equivalent for the `ENABLE` or `DISABLE VMS_PLUS` command.

EXIT

`EXIT` — Closes an open connection and exits from FTP. Pressing `Ctrl/Z` is equivalent to the `EXIT` command.

DCL Syntax

`EXIT`

UNIX Syntax

`quit`

bye

FTP

FTP — The File Transfer Protocol (FTP) command starts an FTP session and does one of the following: displays the FTP prompt (you can enter FTP commands to customize your environment and FTP command processing) or establishes a connection to the specified remote host.

DCL Syntax

FTP [*host* [*port*]] [/USERNAME= *remote_user_name*] [/PASSWORD= *password*] [/INPUT= *input_filespec*]

UNIX Syntax

ftp [*host* [*port*]]

Parameters

host

Optional.

Remote host to which you want to connect.

port

Optional.

Specifies the port to use.

Qualifiers

/INPUT= input_filespec

Optional. If you do not specify the */INPUT* qualifier, FTP takes input from `SYSS$INPUT`. If you specify this qualifier, you must also supply an input file specification. FTP continues to prompt until it has a valid input file specification.

Runs a DCL command file with FTP commands.

/PASSWORD= password

Optional. Default: your password on the local system.

Password for the remote user account to which you want to connect.

/USERNAME= remote_user_name

Optional. Default: your user name on the local system.

Name of the remote user account to which you want to connect.

Examples

1. `$ FTP`
FTP>

Starts an FTP user session without establishing a connection.

2. \$ **FTP WKSITE Return**

```
220 wksite.texts.wrights.com FTP Server (UNIX 13:34:28 EDT) ready
Connected to wren.nest.willow.com.
Name (wksite:parks) Return
```

```
331 Password required for parks.
Password: Return
```

```
230 User parks logged in.
FTP>
```

User PARKS starts an FTP session and connects to UNIX host wksite.

3. \$ **FTP NEWY /USERNAME=BENSON /PASSWORD=WMSWMS**

```
220 NEWY.LINK1.MOA.COM FTP Server (Version 5.0) ready
Connected to NEWY.LINK1.MOA.COM.
331 Username BENSON requires a password.
230 User logged in.
FTP>
```

Starts an FTP session and connects to remote OpenVMS host NEWY in user account BENSON.

GET

GET — The GET command does the following: copies remote files to the local host or copies files from a DECnet node. To use this command, you must have an FTP session with a remote host.

DCL Syntax

```
GET remote_file
  [ local_file ]
  [ /[NO]CONFIRM ]
  [ /FDL]
  [ /[NO]LOWERCASE ]
```

UNIX Syntax

```
get remote_file [ local_file ]
```

```
mget remote_files
```

Parameters

remote_file

Required.

Name of the remote file to copy.

- To copy multiple files, separate the file names with commas or plus signs.
- When you specify multiple remote files, you cannot specify a local file name.

- To copy a file from a remote DECnet node, use the full specification: node name, device, directory, and file name.

local_file

Optional. Default: Same name (without any device or directory names).

New name for the copied file. You cannot specify a local file name if you specify the following:

- Multiple remote files
- Wildcards in the remote file name

Qualifiers

/CONFIRM

Optional. Default: immediate execution.

Asks you for confirmation before executing the copy operation.

/FDL

Optional. Default: no secondary file created.

Uses a secondary file with the copied file's OpenVMS RMS record attributes (if you previously entered a PUT/FDL command). The SET TYPE command determines the type of file:

- Specifying ASCII results in a sequential file with variable records. Select this type when transferring ASCII text files.
- Specifying IMAGE results in a sequential file with fixed records of 512 bytes. Select this type when transferring non-ASCII files such as executable image files.

/[NO]LOWERCASE

Optional. Default: /LOWERCASE

Forces a file name to lowercase at the destination. Use the /NOLOWERCASE qualifier to make sure the file name is preserved in the existing case.

Examples

1. FTP> **get "/seasons/standings/spring.deliveries" SPORTS.TXT**

```
200 PORT command successful
150 Opening ASCII mode data connection for spring.stats.
```

```
.
.
.
```

Copies the UNIX file `spring.deliveries` to an OpenVMS host, where it is named `SPORTS.TXT`.

2. FTP> **GET spring.deliveries SPORTS.TXT**

Copies the same file (`spring.deliveries`) when it is in your remote working directory.

3. FTP> **mget *.doc**

```

200 PORT command successful
150 Opening ASCII mode data connection for cast.doc;1 (130.180.4.8,27)
226 Transfer complete.
local:cast.doc;1  remote: cast.doc;1
1222 bytes received in 00:00:00.01 seconds (70.19 Kbytes/s)
200 PORT command successful
150 Opening ASCII mode data connection for director.doc;3
  (130.180.4.8,28)
226 Transfer complete.
local: director.doc;1  remote: director.doc;3
90 bytes received in 00:00:00.01 seconds (5.49 Kbytes/s)
FTP>

```

Copies all the UNIX files ending with doc.

4. FTP> **get/confirm *.*;***

```

Get EDTINI.EDT ? [Y or N] [Y]: Y
.
.
.

```

Before executing the copy operation for every file in the remote default directory, FTP asks, one by one, to confirm that you want to copy each file.

To confirm mput, mget, and mdelete operations, use the FTP prompt command before entering the mput, mget, and mdelete commands.

```

FTP> prompt
Interactive mode on.
FTP> mget C*
Get CHRONOS ? [Y or N or Q or G] [Y]: y
200 PORT command successful.
150 Opening ASCII mode data connection for CHRONOS (130.180.4.8,2150)
  (1596
bytes).
226 Transfer complete.
local: WORK1$:[VANA]CHRONOS.;2  remote: CHRONOS
1596 bytes received in 00:00:00.04 seconds (31.80 Kbytes/s)

```

5. FTP> **get/fdl feathers.dis**

Copies and preserves the record attributes of feathers.dis. (A put/fdl command was entered previously.)

HELP

HELP — Displays information about how to enter FTP commands.

Additional Information

Provides help for both DCL and UNIX commands, as follows:

- HELP — Displays all DCL FTP commands

- `HELP ftp_command` — Displays DCL help information for the specified command
- `?` — Displays all the UNIX FTP commands
- `? command` — Displays help for the specified UNIX command

DCL Syntax

`HELP [/REMOTE] [command]`

UNIX Syntax

`help [command]`

`? [command]`

Parameters

command

Optional.

FTP command about which you would like information.

Qualifiers

`/REMOTE`

Optional. Default: local host.

The remote host displays FTP help information. If the remote host is a UNIX host, the FTP help is all UNIX style. If you want to display information about a specific command, the `/REMOTE` qualifier must follow the `HELP` command and precede the name of any command for which you want information, as shown in example 2.

Examples

1. FTP> **HELP**

Information available:

| | | | | | | |
|------------|---------|--------|--------|-----------|---------|-----|
| APPEND | CONNECT | CREATE | DELETE | DIRECTORY | DISABLE | |
| DISCONNECT | ENABLE | EXIT | GET | HELP | LOGIN | PUT |
| QUOTE | RENAME | SET | SHOW | SPAWN | VIEW | |

Topic?

The local system displays all DCL FTP commands.

2. FTP> **HELP/REMOTE**

214-The following commands are recognized (* =>'s unimplemented)

| | | | | | | | | |
|-------|------|-------|-------|------|------|------|------|------|
| USER | PORT | STOR | MSAM* | RNTO | NLST | MKD | CDUP | LPSV |
| PASS | PASV | APPE | MRSQ* | ABOR | SITE | XMKD | XCUP | EPRT |
| ACCT* | TYPE | MLFL* | MRCP* | DELE | SYST | RMD | STOU | EPSV |

```

SMNT*  STRU    MAIL    ALLO    CWD     STAT    XRMD    SIZE
REIN*  MODE    MSND*   REST*  XCWD    HELP    PWD     MDTM
QUIT   RETR    MSOM*   RNFR   LIST    NOOP    XPWD    LPRT
                214 End of help
FTP>

```

The remote host, a UNIX system, displays the FTP commands you can use in your FTP session with this system.

3. FTP> **HELP/REMOTE USER**

```
214 Syntax: USER <sp> username
```

```
FTP>
```

The remote host displays information about the FTP command USER.

4. FTP> ?

Commands may be abbreviated. Commands are:

```

append      disconnect  mkdir      remotehelp  view
ascii       form       mls        rename      view/p
bell        get        mode       reset       view/pa
binary     glob       mput      rmdir       view/pag
bye        hash       open      rstatus     view/
page
case        image     prompt    send        vms
cd          lcd       sendport  status      ?
cdup       ls        put       struct      !
close      lpwd     pwd       sunique
delete     mdelete  quit      type
debug     mdir     quote    user
dir        mget    recv     verbose
FTP>

```

Displays FTP HELP about UNIX commands.

LOGIN

LOGIN — Initiates the login process and completes it if no password is required. If a password is required, enter it at the password prompt. Use this command if the connection is active but the login procedure fails when you request a connection.

DCL Syntax

LOGIN *user_name*

UNIX Syntax

user *user_name*

Parameter

user_name

Required.

Your account on the connected remote host.

Example

```
$ FTP
FTP> open bygnet
220 bygnet.band2.stat.com FTP server (UNIX Version 5.60) ready
Connected to bygnet.
Name (bygnet:vana): evt
331 Password required for evt.
Password:
530 Login incorrect.
%TCPIP-E-FTP_LOGREJ, login request rejected
FTP> LOGIN "evt"
331 Password required for evt.
Password:      230 User evt logged in.
FTP>
```

While trying to connect and log in to remote UNIX host `bygnet`, user `evt` enters an incorrect password. Although host `bygnet` completes the connection, `bygnet` rejects the login request. The `LOGIN` command successfully completes the login to the remote host.

PUT

PUT — The `PUT` command does the following: copies local files to a remote host or copies files to a DECnet node. File names are copied in lowercase without version numbers. To use this command, you must have an FTP session with a remote host. For information about file version numbers, see Section 2.8.4.

DCL Syntax

```
PUT [ /CONFIRM | /CONVERT | /FDL | /[NO]LOWERCASE | /RAW ] ( local_file [ remote_file ] )
```

UNIX Syntax

```
put local_file [ remote_file ]
```

```
send local_file [ remote_file ]
```

```
mput local_files
```

Parameters

local_file

Required.

Name of the local file to copy.

- To specify multiple files, separate the names with commas.
- To use wildcards, first enable parsing (see the `ENABLE PARSE` command).

put *file_name.ext* — Copies the latest version

put *file_name.ext*;* — Copies all versions

- To copy a file to a remote DECnet node, use the full specification: node name, device, directory, and file name.

remote_file

Optional. Default: same name, same case, no version number on UNIX systems.

Name of the new file on the remote host. You cannot use wildcards.

Qualifiers

/CONFIRM

Optional. Default: immediate execution. The /CONFIRM qualifier must immediately follow the PUT command, without a preceding space.

This qualifier asks you for confirmation before copying the file.

/CONVERT

Optional.

Translates the internal file-formatting characters of Variable Forms Control (VFC) files. The /CONVERT qualifier must immediately follow the PUT command, without a preceding space.

/FDL

Optional. Default: no secondary file created. The /FDL qualifier must immediately follow the PUT command, without a preceding space.

Creates a secondary file with the file's OpenVMS record attributes. The SET TYPE command determines the type of file.

- Specifying ASCII results in a sequential file with variable-length records. Select this type when transferring ASCII text files.
- Specifying IMAGE results in a sequential file with fixed-length records of 512 bytes. Select this type when transferring non-ASCII files, such as executable image files.

/[NO]LOWERCASE

Optional. Default: /LOWERCASE

Forces a file name to lowercase at the destination. Use the /NOLOWERCASE qualifier to make sure the file name is preserved in the existing case.

/RAW

Optional.

Maintains block mode of files regardless of the TCPIP\$FTP_RAW_BINARY logical name definition. The /RAW qualifier must immediately follow the PUT command, without a preceding space.

Examples

1. FTP> PUT SALES.LIS;*
200 PORT command successful

```

150 Opening ASCII mode data connection for sales.lis.2
(130.180.4.8,1028)
226 Transfer complete
local: DISK3$:[TRANS]SALES.LIS;2 remote: sales.lis.2
3634 bytes sent in 00:00:00.01 seconds (394.31 Kbytes/s)
200 PORT command successful
150 Opening ASCII mode data connection for sales.lis.1
(130.180.4.8,1029)
226 Transfer complete
local: DISK3$:[TRANS]SALES.LIS;1 remote: sales.lis.1
3634 bytes sent in 00:00:00.01 seconds (394.31 Kbytes/s)
FTP>

```

Copies all versions of the local file SALES.LIS to the remote UNIX host.

- File names are copied in lowercase.
- OpenVMS file version numbers become the last element of the copied files.
- Semicolons are converted to periods.
- If the Store Unique feature is toggled on (`sunique`), when you copy a file to an OpenVMS host, the host FTP server gives the file a new, unique version number. When you specify the version number of a file to be copied (PUT) to a remote UNIX host, the file retains the version number on the remote host, with the semicolon (;) replaced by a period (.). The UNIX host adds another version number to the file name as well. For example, if you copy (PUT) file BASES.TMP;2 to a UNIX host, the file name on the UNIX host will be `bases.tmp.2.1`.

2. FTP> PUT/FDL STAT.BCK "cygnet.bck"

```

200 PORT command successful
150 Opening data connection for cygnet.bckfdl (130.180.4.8,1028)
226 Transfer complete
local: cygnet.bckfdl remote: cygnet.bckfdl
21700 bytes sent in 00:00:00.03 seconds (662.23 Kbytes/s)
200 TYPE set to IMAGE
200 PORT command successful
150 Opening data connection for cygnet.bck (130.180.4.8,1029)
226 Transfer complete
local: STAT.BCK remote: cygnet.bck
8152 bytes sent in 00:00:00.12 seconds
FTP>

```

Copies the local file STAT.BCK to a UNIX host, giving the copy the name `cygnet.bck`. Also creates a secondary file with the RMS record attributes of file `cygnet.bckfdl`.

QUOTE

QUOTE — Sends your input directly to the remote host. Lets you use FTP commands that are implemented by the remote host but not known to the local host. To use the QUOTE command, you must have an FTP session with a remote host. The QUOTE command is not valid for file transfer. For a list of commands implemented by the remote host, enter: FTP> HELP/REMOTE

DCL Syntax

QUOTE *command_line*

UNIX Syntax

quote command_line

Parameter

command_line

Required.

Remote command you want to execute.

Example

```
FTP> QUOTE CDUP
250 CWD command successful.
FTP>
```

FTP sends the `cdup` command to the UNIX host to change the remote directory up one level.

RENAME

RENAME — Renames a remote file. To use this command, you must have an FTP session with a remote host.

DCL Syntax

RENAME *old_name new_name*

UNIX Syntax

rename *old_name new_name*

Parameters

old_name

Required.

File name on the remote host to rename.

new_name

Required.

New name for the remote file.

Examples

```
1. FTP> rename STUDENTS.LIS TEST_STUDENTS.LIS

350 File exists, ready for destination name
250 RNTD command successful.
FTP>
```

Renames a file on a UNIX system.

```
2. FTP> RENAME STUDENT.LIS TEST_STUDENT.LIS
```

```
350 File WORK1$:[VANA]STUDENT.LIS; will be renamed.
250 File WORK1$:[VANA]STUDENT.LIS;1 renamed to WORK1$:[VANA]TEST_STUDENT.LIS;1
FTP>
```

Renames a file on an OpenVMS system.

SET DEFAULT

SET DEFAULT — Sets your default directory on either the remote host or the local host. To set the default directory on a remote host, you must have an FTP session with a remote host.

DCL Syntax

SET DEFAULT [/LOCAL] *directory*

UNIX Syntax

cd directory

lcd directory

Parameter

directory

Required.

Name of the directory to which to change the default.

Qualifier

/LOCAL

Optional. Default: remote.

Changes the working directory on the local host.

Examples

```
1. FTP> SET DEFAULT "/USR/USERS/ROLLINGS"
250 CWD command successful.
```

Changes the remote working directory to /usr/users/rollings.

```
2. FTP> SET DEFAULT ~
250 CWD command successful.
250 New default directory is /USR/USERS
```

Changes the remote working directory back to the default login directory.

```
3. FTP> SET DEFAULT /LOCAL USER$1:[PRESS.CHECK]
Local Directory now USER$1:[PRESS.CHECK]
```

Changes your local working directory to USER\$1:[PRESS.CHECK].

SET ERROR_LEVEL

SET ERROR_LEVEL — Sets maximum tolerance level for errors.

Additional Information

The error tolerance levels are:

- ERROR — FTP tolerates errors and warnings and does not exit when running in batch mode.
- SUCCESS — The default. FTP does not tolerate errors and exits when running in batch mode.
- WARNING — FTP tolerates warnings and does not exit when running in batch mode.

DCL Syntax

```
SET ERROR_LEVEL error_level
```

UNIX Syntax

There is no UNIX equivalent for the SET ERROR_LEVEL command.

Parameters

error_level

Required.

Severity of errors tolerated. Specify ERROR, SUCCESS, or WARNING. The default is SUCCESS.

Example

```
FTP> SET ERROR_LEVEL ERROR
Error level is ERROR.
```

Sets the error level tolerance to ERROR.

SET PASSIVE

SET PASSIVE — Controls whether the FTP client or server initiates data connections.

DCL Syntax

```
SET PASSIVE keyword
```

UNIX Syntax

passive keyword

Parameter

keyword

The FTP client program starts with the value AUTO. All keyword comparisons are done without regard for typographical case (case-blind).

- ALL

Does nothing.

- AUTO

The FTP client uses the version of network protocol in use on the control connection to determine how the data connection is initiated. If the network protocol is IPv4, FTP client behaves as though SET PASSIVE OFF had been specified. If the network protocol is IPv6, FTP client behaves as though SET PASSIVE ON had been specified.

- OFF

The FTP server initiates the data connection.

- ON

The FTP client initiates the data connection. This is often useful when a network firewall exists on the path between the client and the server and prevents the FTP server from making outbound connections.

Example

1. FTP> **SET PASSIVE ON**
Passive is ON

Sets passive mode to ON. The FTP client always initiates the data connection.

2. FTP> **PASSIVE AUTO**
Passive is AUTO (IPv4: OFF, IPv6: ON).

Sets passive mode back to AUTO.

SET TYPE

SET TYPE — Defines the data representation type: ASCII (appropriate for text files, default) or IMAGE (appropriate for transferring binary files, such as executable images.).

DCL Syntax

SET TYPE *type*

UNIX Syntax

type type

Parameter

type

Required.

Data representation type. Specify ASCII or IMAGE. If you do not use the SET TYPE command, the default is SET TYPE ASCII.

Example

```
FTP> SET TYPE IMAGE
200 Type set to I.
```

Sets the data representation type to IMAGE for files you transfer during the current FTP session.

SHOW DEFAULT

SHOW DEFAULT — Displays the name of the working directory on the remote host or the local host. To use the SHOW DEFAULT command to display the working directory on the remote host, you must have an FTP session with a remote host.

DCL Syntax

```
SHOW DEFAULT [ /LOCAL ]
```

UNIX Syntax

pwd

Qualifier

/LOCAL

Optional. Default: remote directory.

Displays the local working directory.

Examples

1. FTP> **SHOW DEFAULT**
257 "/usr/staff/hurry/items" is current directory.

Displays the name of the working directory on the connected remote host.

2. FTP> **SHOW DEFAULT /LOCAL**
Local directory is WORKS\$:[CROWE].

Displays the name of the working directory on the local host.

SHOW PASSIVE

SHOW PASSIVE — Displays the current setting of the FTP client passive parameter.

Syntax

```
SHOW PASSIVE
```

Example

```
FTP> SHOW PASSIVE
Passive is AUTO (IPv4: OFF, IPv6: ON).
```

Shows that passive mode is on for IPv6.

SHOW STATUS

SHOW STATUS — Displays the current FTP parameter settings and, if you have an open connection, the name of the connected host and parameter settings relative to the connection.

DCL Syntax

SHOW STATUS

STATUS

UNIX Syntax

status

rstatus

Examples

1. FTP> **SHOW STATUS**
211-FTP Server Status.
211-SITE set to +VMS+.
211-TYPE set to ASCII.
211-STRU set to FILE.
211-MODE set to STREAM.
211 Multiline responses are enabled.
Connected to: HANKS.ABC.UCB.EDU
VMS Plus mode enabled
Mode = stream, Type = ascii, Form = non_print, Structure = file
Error level is SUCCESS
Passive is AUTO (IPv4: OFF, IPv6: ON)

Displays the status of the connection with remote OpenVMS host HANKS. By default, FTP sets VMS Plus Mode for rapid file transfers between two OpenVMS systems running TCP/IP Services for OpenVMS.

2. FTP>**status**

211-FTP Server Status.
211-SITE set to +VMS+.
211-TYPE set to ASCII.
211-STRU set to FILE.
211-MODE set to STREAM.
211 Multiline responses are enabled.
Local client's status:
Connected to:HANKS.ABC.UCB.EDU
VMS Plus mode enabled
Mode = stream, Type = ascii, Form = non_print, Structure = file

```

Error level is SUCCESS
Passive is AUTO (IPv4: OFF, IPv6: ON)
Reply display is on
Parsing is on
Prompting is off
Port command is on
Case: MPUT will preserve typographical case in destination filenames,
  if
possible

```

Is a superset of the SHOW STATUS command. The output is consistent with running the status command on other platforms.

3. FTP> **show status**

```

211-eagle.store1.equip.com FTP server status:
  Version 5.60
  Connected to eagle.store1.equip.com
  Logged in as jones
  TYPE: Image; STRUCTure: File; transfer MODE: Stream
  211- No data connection
211 End of status
Connected to: eagle
VMS Plus mode disabled
Mode = stream , Type = image, Form = non_print, Structure = file
Error level is SUCCESS
Passive is AUTO (IPv4: OFF, IPv6: ON)

```

Displays the current FTP parameters, which control data transfers with the connected UNIX host eagle.

SPAWN

SPAWN — Suspends the current FTP session, creates a subprocess, and runs the DCL command that you type. Use the LOGOUT command to end the subprocess and return to the FTP prompt.

DCL Syntax

SPAWN[*command*]

UNIX Syntax

! [*command*]

Examples

1. FTP> **SPAWN SHOW DEFAULT**
SYS\$LOGIN_DEVICE: [PERCY.DISTR]

Interrupts the FTP process to display your default directory.

2. FTP> **! SHOW DEFAULT**
WORK1\$: [VANA.FTP]
FTP>

You can also use the exclamation point (!) to spawn a command.

For more examples, see Section 2.12.

VIEW

VIEW — Displays the contents of a file on your current output device.

DCL Syntax

VIEW [/PAGE] *filespec*

UNIX Syntax

view *filespec*

Parameter

filespec

Required.

Specifies the file to be displayed. Wildcard characters (*, %) are not allowed in place of the directory name, file name, file type, or file version number.

Qualifier

/PAGE

Optional.

Displays one screen at a time until the end of file (EOF) is reached. You can terminate the display at any time by pressing Ctrl/Z.

Examples

1. FTP> **VIEW FUNDING.TXT**

Scrolls through the contents of the FUNDING.TXT file in the current working directory, and displays the contents on the current output device.

2. FTP> **VIEW/PAGE FUNDING.TXT**

Displays the contents of the FUNDING.TXT file, one screen at a time, on the current output device.

Chapter 3. Using Remote (R) Commands

The Remote (R) commands provided by TCP/IP Services allow you to work in user accounts on remote systems that support the Remote (R) protocols. You can also use commands, shell scripts, and command procedures on these remote host systems without logging in to the hosts. The R commands include RCP (Remote Copy), RLOGIN (Remote Login), RSH (Remote Shell), and REXEC (Remote Execute, invoked by RSH). You enter these commands at your system command-line prompt.

To use the Remote (R) commands, you need access to a user account on the remote host. Access is granted by either of the following:

- An entry in the remote host's authentication or proxy files
- Knowledge of a valid remote account and its password

Table 3.1 summarizes the Remote (R) commands. (For complete command descriptions, see Section 3.8.)

Table 3.1. Summary of Remote (R) Commands

| Command | Description |
|--------------|---|
| RCP | Copies files between the local host and a remote host or between two remote hosts. Authentication is performed on the remote host or hosts using the user name supplied by RCP or by authentication or proxy files. |
| RLOGIN | Connects to the remote host, which starts an interactive login session. Authentication is performed on the remote host using the user name supplied by RLOGIN. |
| RSH | Connects to the remote host, which executes the command you specified. Authentication is performed on the remote host using the user name supplied to RSH. |
| RSH/PASSWORD | Uses the REXEC facility to connect to the remote host, which executes the command you specify. Authentication is performed on the remote host using the user name and password supplied by RSH. |

3.1. Providing Account and Password Information

To use a remote command on your OpenVMS system, remote hosts need to know the user name that you want to use on the host. You can provide the user name in either of two ways:

- Automatically: You do not need to take any action if your user name is the same on the remote host as it is on the local host. The remote commands automatically supply your local user name as the requested user name on the remote system.

- Using the /USER_NAME qualifier: Specify the user name with the /USER_NAME qualifier if your user name is:
 - Different on the remote host
 - In mixed case (only for remote hosts that support case-sensitive user names)
 - The same on the remote host but you want to access the remote host using another user name

By default, the R commands send all user names in lowercase letters. If you access a host that supports case-sensitive user names, and the user name you specify has uppercase letters, you can use the /NOLOWERCASE qualifier to maintain these letters as uppercase, or you can specify the /USER_NAME qualifier and enclose the user name within quotation marks.

The remote host must also know your password or know you as a trusted user on your local system through a proxy or by authentication.

- Accessing remote hosts by providing your password:
 - Certain systems have case-sensitive passwords. To send your lowercase or mixed-case password to these hosts, enclose it within quotation marks (" "). On systems that are not case sensitive, you do not need to enclose your password within quotation marks.

- You can specify the password on the command line, as follows:

```
$ RSH WOODS /PASSWORD="Downy" LS
```

You can specify the password when the remote system prompts, as follows:

```
$ RSH WOODS /PASSWORD DIR
REXEC password:          (password not echoed)
```

- Accessing remote hosts as a trusted user:

Most systems use authentication files or proxy accounts that allow trusted users on trusted hosts to access the system by specifying only the user name they want to use. To access a host without specifying the corresponding password, your originating host and user name must have an entry in these authentication files.

The authentication file entries contain your originating user name. The R commands convert your originating user name to lowercase unless you use the /NOLOWERCASE qualifier. You may have to contact the system manager of the remote system to determine whether the system is case sensitive and, if so, what case is used in the authentication files.

Notes

- To use the REXEC feature, you must always use the /PASSWORD qualifier.
- The RLOGIN command does not recognize the /PASSWORD qualifier. If you are a trusted user, you are automatically logged in to the remote system.
- If you are not a trusted user, the remote host (REXEC) prompts you to enter a user name and password on the remote system.

3.1.1. Quotation Marks

Use quotation marks (" ") for UNIX host path names that include slashes (/), such as `user/simms/offers`, and for user/host specifications that include the `username@hostname` syntax.

If the remote host uses case-sensitive user names and passwords, use quotation marks in the following situations:

- User names and passwords are mixed case.
- Passwords are lowercase.
- User names are uppercase, unless you use the `/NOLOWERCASE` qualifier.

3.1.2. Examples

The following examples show how to provide account and password information for the R commands.

1. OpenVMS user STALLINGS accesses the file `accnts` on UNIX host `ufemism` as user `stallings`, and copies the file to the current directory on the OpenVMS system. Because `/LOWERCASE` is the default, the `/LOWERCASE` and `/USER_NAME=STALLINGS` qualifiers are not needed. In the following example, the user is a trusted user.

```
$ RCP UFEMISM:ACCNTS [ ]
$
```

2. From OpenVMS, user STALLINGS accesses the account `cris` on `ufemism`. Because `/LOWERCASE` is the default, the `/LOWERCASE` and `/USER_NAME=STALLINGS` qualifiers are not needed. In the following example, the user is a trusted user.

```
$ RLOGIN /USER_NAME=CRIS UFEMISM
Welcome to UNIX system ufemism.
.
.
.
ufemism%
```

3. User FINCH has the same uppercase name for both an OpenVMS account and a UNIX account. For RSH to send the uppercase OpenVMS account name to remote host `ufemism` in uppercase, FINCH uses the `/NOLOWERCASE` qualifier. In the following example, the user is a trusted user.

```
$ RSH /NOLOWERCASE UFEMISM CAT -N GRANTS
```

4. User BACH has the account `bach` on the UNIX host `classics`. To invoke the REXEC feature, BACH specifies the password on host `classics`. Note that the password `MagNificat` is enclosed in quotes to prevent RSH from sending it all uppercase.

```
$ RSH /PASSWORD="MagNificat" CLASSICS LS
```

3.2. Specifying Qualifiers

You can specify R command qualifiers in either of two ways:

- Enter the qualifiers on the command line, as follows:

```
$ RCP /LOG TRANQUIL:VULTURES [ ]
$ RSH /EIGHTBIT /ESCAPE_CHAR="+" /TRUNCATE HERON CAT -N STREAMS
```

- Add the same information to your LOGIN.COM file, as shown in the following example:

```
$ ! To customize my R commands:
$ !
$ RCP ::= RCP /LOG
$ RLOGIN ::= RLOGIN /EIGHTBIT/ESCAPE_CHAR="+" /TRUNCATE_USER_NAME
$ RSH ::= RSH /EIGHTBIT /ESCAPE_CHAR="+" /TRUNCATE_USER_NAME
$ !
```

3.3. Obtaining Online Help

You can obtain online help for the Remote commands by entering the following command:

```
$ HELP TCPIP_SERVICES REMOTE_COMMANDS
```

You can also obtain information for a specific R command by entering one of the following commands:

```
$ HELP RCP
$ HELP RLOGIN
$ HELP RSH
$ HELP REXEC
```

3.4. Copying Files with RCP

The RCP (Remote Copy) command copies a file between your local host and a remote internet host. You can also use RCP to copy a file between two remote internet hosts. You specify the source and destination file names, each in the format appropriate for the source or destination system. For copying files from one remote host to another, the following rules apply:

- If you do not have proxy login accounts (or authentication file entries) for both the source and remote hosts, you must have the same user name and password on both source and destination hosts. Use the /PASSWORD qualifier and, if necessary, the /USER_NAME qualifier, to specify the authentication information for the remote hosts.
- If you have a proxy login account (or authentication file entry) on one of the remote hosts only, use the /PASSWORD qualifier and, if necessary, the /USER_NAME qualifier to specify the authentication information for the other host.

To recursively copy every file and subdirectory in a directory, use the /RECURSIVE qualifier with the RCP command.

To preserve file format and other attributes when copying files between two OpenVMS systems, use the /VMS qualifier (UNIX format: -v option). For more information, see Section 3.4.1.

You can also use the COPY/RCP command to copy files across the network. For more information on this command, enter HELP COPY/RCP at the DCL prompt.

Note that you can also use FTP to transfer files. To determine the best file transfer service to use for your needs, see Section 1.1.1. For more information about FTP, see Chapter 2.

3.4.1. Notes About File Formats

RCP on OpenVMS is best used for transferring text files. By default, RCP converts any type of OpenVMS file that is not `STREAM_LF`, `FIXED`, or `UNDEFINED` to `STREAM_LF` format, using the standard OpenVMS `CONVERT` utility. RCP specifies the files in the following way:

```
FILE;ORGA SEQU;RECO;CARR CARR;FORM STREAM_LF;SIZE 0;BLOCK YES
```

Options available for changing the default behavior for file copy operations include the following:

- Convert `FIXED` and `UNDEFINED` format files to `STREAM_LF`

You can change the behavior of RCP to convert `FIXED` and `UNDEFINED` format files to `STREAM_LF` format by using the following logical name:

```
TCPIP$RCP_SEND_FIX_FORMAT_AS_ASCII
```

If this logical name is set to the value 1, RCP converts `FIXED` and `UNDEFINED` files to `STREAM_LF` format. If this logical name is set to a value other than 1, RCP will not convert those files that have a fixed-length record size that matches the value of the logical name; RCP will convert all other `FIXED` and `UNDEFINED` files.

For example, if you set this logical name to 512, RCP will not convert `FIXED` or `UNDEFINED` files with a fixed-length record size of 512 (such as OpenVMS executable image files); RCP will convert all other `FIXED` and `UNDEFINED` files.

- Preserve File Attributes in OpenVMS-to-OpenVMS File Transfer.

In an OpenVMS-to-OpenVMS transfer, the receiving peer creates the file as a `STREAM_LF` file by default. You can preserve the file type and other attributes of a file transferred between two OpenVMS systems by using the `/VMS` qualifier (UNIX format: use the `-v` option) with the RCP command.

Warning

Specify this qualifier only for file copy operations between two OpenVMS systems; otherwise, the operation will fail.

3.4.2. Notes About File Size

When transferring files, the RCP protocol requires that the length of the file be sent as part of the protocol. The length is interpreted as a signed 32-bit integer. Therefore, files transferred using RCP must be less than 4 GB minus 1 byte.

3.4.3. Example RCP Commands

The following examples show how to use RCP commands to copy files from one host to another host:

1. User `BEST` has the account `best` on the UNIX host `haven`. User `BEST`'s password for that account is `IMusici`, which must be enclosed in quotation marks because it is mixed case. The following command copies the file `/symp/nine` on `haven` to the local directory on the OpenVMS system (the UNIX file specification also must be enclosed in quotation marks):

```
$ RCP /PASSWORD="IMusici" "haven:/symp/nine"
```

2. User BEST has a proxy account on the remote UNIX host `musicx`. The following command copies the file `/symph/pastoral` from host `musicx` to the directory `[SYMPH6]` on the device `DKA300`: on BEST's local OpenVMS system:

```
$ RCP "musicx:/symph/pastoral" ":DKA300:[SYMPH6]"
```

3. With the following command, user BEST copies each subtree rooted at the `/symph` directory to the directory `[SYMPHS]` on the device `DKA300`: on BEST's local OpenVMS system.

```
$ RCP/RECURSIVE "haven:/symph" ":DKA300:[SYMPHS]"
```

4. With the following command, user BEST copies all files from the directory `/symphonies` on remote host `musicx` to the directory `/symph` on remote host `haven`:

```
$ RCP /PASSWORD="IMusici" "musicx:/symphonies/*" "haven:/symph/*"
```

5. In the following example, user BEST uses the DCL command `COPY/RCP` to transfer the complete subdirectory tree `/symph` from remote UNIX host `haven` to remote OpenVMS host `FRAM`. Both hosts require a password. (When using the `RCP` command to transfer files between two remote hosts, you need a proxy account or an entry in the authentication file for at least one of the two remote hosts.) User BEST has an account under the same name on both hosts.

```
$ COPY/RCP haven"BEST IMusici"::"/symph/*"  
To: FRAM"VAUGHN MYLES"::[classic.compositions]*"
```

3.5. Starting a Remote Login Session with RLOGIN

The `RLOGIN` (Remote Login) command connects your terminal to the remote host you specify and requests a login. If the remote host has an entry in its authentication files for your host and user name, it may bypass its login and password prompts. (See Section 3.1.)

Note that you can also use `TELNET` to log in to remote internet hosts. To determine the best remote login service to use for your needs, see Section 1.1.2. For more information about `TELNET`, see Chapter 4.

3.5.1. Logging Out

End your remote login session in one of the following ways:

- Log out from the remote host.
- On a new line, enter the escape character and a period.

The default escape character is a tilde (`~`). To set another escape character, use the `ESCAPE_CHARACTER` qualifier on the `RLOGIN` command line.

3.5.2. Example RLOGIN Sessions

The following examples show how to use the `RLOGIN` command.

1. The following command logs in to node `CONDO`:

```
$ RLOGIN CONDO  
CONDO - Unauthorized access is prohibited
```

```

Username: KING
Password: (password not echoed)
  Welcome to OpenVMS (TM) Alpha Operating System, Version V7.3 on node
  CONDO
      Last interactive login on Thursday, 24-SEP-2001 15:20:29.60
      Last non-interactive login on Wednesday, 23-SEP-2001
  14:25:04.12
$ RUN ...
$ ~. (characters not echoed)
%RLOGIN-S-LCLCLOSED, Local connection closed
$

```

2. The following command logs in to host `petrel` and changes the character used to close the RLOGIN session:

```

$ RLOGIN /ESCAPE_CHARACTER="+" PETREL
.
.
.
Last login: Mon Mar 14 18:34:27 from phoebe.edu
UNIX System petrel:  Fri Mar 19 11:02:20 EST 2002
Mon Jun 28 18:44:42 EST 2002
%ls ...
%+. (characters not echoed)
%RLOGIN-S-REMCLOSED, Remote connection closed
$

```

3.6. Issuing a Remote Command with RSH

The RSH (Remote Shell) command connects your terminal to a remote host and requests it to execute the command, script, or command procedure that you specify. If the command generates output, you see it as if it were produced locally. If you omit a remote command when you enter an RSH command line, RSH initiates an RLOGIN session. However, if the command line includes the `/PASSWORD` qualifier, the remote login attempt fails. Using the `/PASSWORD` qualifier invokes REXEC. (See Section 3.7.)

Syntax rules require that you enter your RSH command line so that the remote command is the last word.

3.6.1. Quotation Marks in Commands

If the remote command is one or more lowercase words, you do not need to enclose them in double quotation marks on the RSH command line. However, double quotation marks (") are required for the following:

- Mixed-case UNIX commands
- Uppercase UNIX commands

In addition, RSH handles one double quotation mark (") and two consecutive double quotation marks (" ") in the following manner:

- If you enter one double quotation mark on a command line, RSH removes it.
- If you enter two consecutive double quotation marks on the command line, RSH removes the first quotation mark and leaves the second.

- If you enclose text within double quotation marks on a command line, RSH disables the default conversion of characters to lowercase and removes the quotation marks.

Note that, as a general rule, if you are uncertain about whether or not to use quotation marks, you should use them.

3.6.2. Interrupting a Command's Execution

To stop remote execution of a command, press either Ctrl/C or Ctrl/Y.

3.6.3. Example RSH Commands

The following examples show how to use the RSH command.

1. In the first example, the remote system manager previously created an entry in the authentication files for remote user STAN on host oster, giving STAN permission to access user roolly.

From the local OpenVMS host, user STAN views roolly's directory, which resides on UNIX system oster. No quotation marks are required around the user name and host name because RSH by default sends them in lowercase.

```
$ RSH /USER_NAME=ROLLY OSTER LS
```

2. On the following RSH command line, the uppercase UNIX qualifier -R is entered within quotation marks to preserve the uppercase R. This example assumes that the user's originating host and user name are in the authentication files on the remote host debts.

```
$ RSH DEBTS LS "-R"
```

3. The following commands show how RSH sends quotation marks to a remote UNIX host and how quotation marks affect case. All examples assume that the user's originating host and user name are in the authentication files on the remote host.

```
$ RSH DEBTS ECHO TEST MESSAGE
test message
$ RSH DEBTS ECHO "
\""test
\"" message"
"test" message
RSH DEBTS ECHO "TEST" MESSAGE
TEST message
$ RSH DEBTS "echo '"test"' message'"
"test" message
```

4. Because a remote command is not specified on the RSH command line, TCP/IP Services executes RLOGIN.

```
$ RSH MOON01
Password:      Return(password not echoed)
Last successful login for jjones: Fri Sep 25 10:58:31 2003 from nebula
      Last unsuccessful login for jjones: Fri Sep 25 11:59:43 2003 on
      tty5
      Tru64 UNIX V5.0 (Rev. 148); Tue Apr 7 18:32:54 EST 2003
                        Compaq Computer Corporation
                        Internal Use Only
moon01>
```

5. In this example, the OpenVMS system manager of host WR2 previously created an entry in the authentication files for remote user SIMMS on host WR1.

From OpenVMS host WR1, user SIMMS enters the DIRECTORY command to execute at host WR2.

```
$ RSH WR2 DIRECTORY
```

6. In this example, the OpenVMS system manager of host WR2 previously created an entry in the authentication files for remote user SIMMS on host WR1, allowing user SIMMS access to the user name ROGERS.

User SIMMS enters the DIRECTORY command from host WR1 to execute at host WR2 in user account ROGERS.

```
$ RSH WR2 /USER=ROGERS DIRECTORY
```

3.7. Issuing a Remote Command with a Password (REXEC Feature)

Use the REXEC feature to send a command to execute on a remote host that does not have, or might not have, the authentication information that RSH requires. The remote system's authentication files are not used.

Along with the remote command, REXEC sends the password you specify on the command line to the remote host. This password is used for security checking.

The Remote Shell program (RSH) invokes REXEC. To use REXEC, enter RSH /PASSWORD. REXEC then functions like the RSH command.

3.7.1. Example of Using REXEC

The following example shows how to provide password information for the RSH command, thereby invoking the REXEC feature on the remote host.

From host GRANT, user STANTON enters the file `tops.holdings` that resides on UNIX host `oster`. Because STANTON is not listed in `oster`'s authentication files, user STANTON must use the REXEC feature and supply the `/USER_NAME` and `/PASSWORD` qualifiers. Quotation marks are required around the password because it contains uppercase letters.

```
$ RSH OSTER /USER_NAME=STANTON /PASSWORD="KeepingSaneJoy" -  
_ $ CAT TOPS.HOLDINGS
```

3.8. Command Descriptions

This section provides complete descriptions of each R command. Included with each command description is the UNIX equivalent of the command. These equivalents are valid on UNIX systems only. They are presented here for users who are familiar with the UNIX environment to help them understand the nature of R commands.

RCP

RCP — Copies files between internet hosts. Enter the RCP command at the DCL prompt. You can copy files as follows: from a remote host to your host, from your host to a remote host, from one

remote host to another remote host. You can specify qualifiers in either DCL format or UNIX format, but do not mix both types on the same command line.

DCL Syntax

```
RCP [qualifier(s)[...]] source_file destination_file
    [/[NO]LOG ]
    [ /PASSWORD[=password] ]
    [ /[NO]PRESERVE ]
    [ /[NO]RECURSIVE ]
    [ /TRUNCATE_USER_NAME[=n] ]
```

UNIX Syntax

```
rcp [-p] [-r] [/source_file] [/destination_file]
```

This format is valid only on UNIX systems.

Parameters

source_file

Required.

Source host and file specification in the format "*username@*"*host*:*file*, where:

- *username@* is the user name on a remote UNIX system. This is needed only if the UNIX system has the name in its `/etc/hosts.equiv` file or in the UNIX user's `.rhosts` file. Enclose the *username@* portion, or the entire specification containing the *username@* syntax, in quotation marks (" ").
- *host* is the remote host.
- *file* is the name of the file to copy. A file name without the full path specification defaults to the default (or home) directory. Table 3.2 shows the possible formats.

Table 3.2. Specifying Source Files with the RCP Command

| Host | Possible Formats |
|------------|---|
| UNIX hosts | <p>Specify the following, enclosing UNIX path names that include slashes (/) in quotation marks (" "):</p> <ul style="list-style-type: none"> • Absolute path name, such as <code>/etc/user/hosts</code>, followed by the file name: <pre>% RCP/USER_NAME="jjones"/ PASSWORD="letmein" STATS.TXT - sysair: "/usr/users/jamesj/ stats.txt"</pre> • Path name relative to your default directory, followed by the file name: |

| Host | Possible Formats |
|---------------|---|
| | <pre>% RCP/USER_NAME="jjones"/ PASSWORD="letmein" STATS.TXT - sysair:"~jamesj/stats.txt"</pre> |
| OpenVMS hosts | <p>Specify the following:</p> <ul style="list-style-type: none"> • Brackets ([]), which indicate your default directory, followed by the file name: <pre>\$ RCP/USER_NAME=JJONES/ PASSWORD=LETMEIN OUR.DOC SYSAIR: []GROUP.DOC</pre> • Full file specification, such as DKA0: <pre>[WILDE.BIRDS.NORTHERN]CHAPTER1.TXT.</pre> <p>To specify a device name, enter a colon ":" and then the name. Enclose the entire parameter within quotation marks " ".</p> <pre>\$ RCP/USER_NAME=JJONES/ PASSWORD=LETMEIN CHAP1.TXT - _ \$ SYSAIR:"DKA0: [WILDE.BIRDS.NORTHERN]CHAPTER1.TXT"</pre> • A logical name, such as SYS <pre>\$LOGIN:ROBIN.DAT or DIAK\$9: [AMERICAN]FINDINGS.LIS.</pre> <p>To specify a logical name, enter a colon ":" and then the name. Enclose the entire parameter within quotation marks " ".</p> <pre>\$ RCP/USER_NAME=JJONES/ PASSWORD=LETMEIN CHAP1.TXT - _ \$ SYSAIR:"SYS\$LOGIN:CHAPTER1.TXT"</pre> |

destination_file

Required.

Destination host and file specification information is of the same form as the source parameter, unless the file specification is completely omitted or the file name portion of the file specification is omitted. In these cases, the default file name used is the same as specified in the source parameter, the directory being the default (home) directory of the user.

Qualifiers

/LOG
/NOLOG

Optional. Default: no logging.

Displays information about files as they are copied to or from the local system.

`/PASSWORD= password`

Required if `/USER_NAME` qualifier is used.

Password on the source or destination host system (whichever requires authentication).

`/PRESERVE`

`/NOPRESERVE`

Optional.

Preserves the file protection mode and modification date during a copy. The creation date and modification date of the output file are set to the modification date of the input file. The dates are truncated to the second on transfer. When these dates are displayed on OpenVMS, the "hundredths of a second" field will always be zero.

When a file is created by RCP/PRESERVE on an OpenVMS system running TCP/IP Services, WRITE permission on the input file grants both WRITE and DELETE permission on the output file.

`/RECURSIVE`

`/NORECURSIVE`

Optional.

Recursively copies each subtree rooted at the directory you specify in the UNIX file specification. For OpenVMS hosts, specify [*directory...*] (with three trailing periods) in the file specification instead of using this qualifier.

`/TRUNCATE_USER_NAME[= n]`

`/NOTRUNCATE_USER_NAME`

Optional. Default: no truncation.

Truncates the user name to the specified number of characters. If you omit *n*, the default is 8 characters.

`/USER_NAME= remote_user_name`

Optional. Default: current name on local host in lowercase.

Specify user name on the source or destination remote host. Use only if an entry allowing access to this user has not been added to the remote host's authentication files. You must also specify the `/PASSWORD` qualifier with the `/USER_NAME` qualifier. Specifying "username@" with the source or destination parameter is the equivalent UNIX style method.

Examples

1. `$ RCP/LOG NYX:STATS.BNT []`

Copies file `stats.bnt` from remote UNIX system `nyx` from under its home directory to a local file of the same name in the current directory. The `/LOG` qualifier causes information for the copy to be displayed. This command assumes the user has an entry in the authentication file on host `nyx`.

2. **\$ RCP HIAIR1:AIRFRS.TXT [FLTAT.STATS]FARES1.TXT**

Copies file AIRFRS.TXT from its home directory on remote OpenVMS system HIAIR1, to a local file of a different name (FARES1.TXT) in the specified directory. This command assumes the user has an entry in the authentication file on host HIAIR1.

3. **\$ RCP /PRESERVE HIAIR1:[FARES.SUMMER]FARES_SU.TXT ":DKA300:[]"**

Copies file FARES_SU.TXT from directory [FARES.SUMMER] on remote OpenVMS system HIAIR1 to the specified device and directory on the local system. The new file maintains the same name as the original. The copy preserves the source file's protection mode and modification date.

Note the use of quotation marks (" ") to specify the device and directory on the destination.

4. **\$ RCP /USER=MILLER /PASS="AirOut" ":SYS\$LOGIN:PILOTS.LIS" FALCON:**

Copies file PILOTS.LIS from the login directory of user MILLER on the local system to the user's login directory on a remote UNIX system. The user specifies the user name and password for access to the UNIX system (the password is specified in quotation marks to preserve the mixed case letters).

Note the use of quotation marks (" ") to specify the SYS\$LOGIN device and file name on the destination.

5. **\$ RCP /RECURSIVE ":DKA300:[MILES...]" "nyx:/usr/tmp"**

Copies all files and any subdirectories in local directory [MILES] to a remote UNIX host's destination directory. All the files in the subdirectories are copied as well, creating subdirectories as appropriate on the remote host. The directory hierarchy is preserved on the UNIX host by default. This command assumes the user has an entry in the authentication file on host nyx.

6. **\$ RCP /LOG /RECURSIVE [MILES...] BOSTON:[FRFL...]**

Copies the complete local subdirectory tree ([MILES...] and all subdirectories) to the destination directory on remote OpenVMS host BOSTON, while preserving the directory hierarchy and logging each file copy. This command assumes the user has an entry in the authentication file on host BOSTON.

7. **\$ RCP /LOG /RECURSIVE [MILES...] BOSTON:[FRFL]**

Same as example 6, except that all files in the local directory tree are copied directly to the destination directory itself. The command does not preserve the directory hierarchy of [MILES...] in [FRFL] on host BOSTON. That is, the command does not create new subdirectories in BOSTON:[FRFL]; it copies all the files in [MILES] and all its subdirectories to directory [FRFL].

8. **\$ RCP /USER=VAUGHN /PASSWORD=MYLES /TRUNCATE=6 STATS.TXT FRAM:TISTICS**

Copies the local file STATS.TXT to a remote user's login directory. Note the truncation of the remote user name. A user name and password are necessary if no entries for the user are present in the remote host's authentication files.

9. **\$ RCP BOSTON:NAMES.LIS FRAM:ROSTER.LIS**

Copies file NAMES.LIS from remote host BOSTON to remote host FRAM (naming the file ROSTER.LIS). Assumes that appropriate entries for the user have been made in each remote host's authentication files.

```
10. $ RCP "MILLER@BOSTON:SYS$DIR:T2.TXT" "nelson@nyx:/usr/nelson/T2.TXT"
```

Copies file T2 from remote OpenVMS system BOSTON in the directory pointed to by the logical name SYS\$DIR to remote UNIX system nyx in the specified directory. Different user names are used on the two remote systems. Entries in the remote host's authentication files must be set up properly because the passwords are not being passed.

```
11. $ RCP /USER=ROSS /PASSWORD=LC12LC BOS:CLIENT.LIS "BEX:/usr"
```

Copies file CLIENT.LIS from OpenVMS host BOS to UNIX host bex. The user has a proxy account on the UNIX host. The specified authentication information allows access to the account for ROSS on host BOS.

REXEC

REXEC — Sends a command line to a specified remote host for execution.

Additional Information

The difference between the REXEC facility and RSH is security checking:

- REXEC — The remote host bases authentication on the supplied user name and password.
- RSH — The remote host bases authentication on user name and information in the remote system's authentication files.

To invoke the REXEC feature, enter one of the following:

```
RSH /PASSWORD=password
```

or

```
RSH /PASSWORD
```

For more information, see the RSH command with the /PASSWORD qualifier.

RLOGIN

RLOGIN — Initiates an interactive login session with a remote host.

DCL Syntax

```
RLOGIN /DROP_TIMEOUT=seconds host  
    [ /EIGHTBIT ]  
    [ /ESCAPE_CHARACTER=character ]  
    [ /LOG_FILE=file ]  
    [ /[NO]LOWERCASE ]  
    [ /PROBE_TIMEOUT=seconds ]  
    [ /TERMINAL_SPEED=baud ]  
    [ /TERMINAL_TYPE=type ]  
    [ /[NO]TRUNCATE_USER_NAME ]  
    [ /USER_NAME=remote_user_name ]
```

UNIX Syntax

```
rlogin host [ -8 ] [ -e c ] [ -l remote_user_name ]
```

Parameter

host

Required.

Remote host to which you want to connect.

Qualifiers

/DROP_TIMEOUT= seconds

Required if you set */PROBE_TIMEOUT*.

Maximum interval, in seconds, that your network link can be down before the software closes it.

/EIGHTBIT

-8 (valid only on UNIX systems)

Optional. Default: only 7-bit data is sent.

Accepts 8-bit data from the terminal and sends it to the remote system.

/ESCAPE_CHARACTER= character

-e *c* (valid only on UNIX systems)

Optional. Default: ~ (tilde).

New escape character if you want to close your RLOGIN session from the remote host.

To close your session from your local host, use a period (.) as the escape command.

/LOG_FILE= file

Optional. Default: no logging.

Logs a copy of the output to the specified file. Output continues to be directed to SYSS\$OUTPUT while it is being recorded in the log file.

/LOWERCASE

/NOLOWERCASE

Optional. Default: */LOWERCASE*.

Sends your local user name to the remote host in lowercase.

To send your user name in uppercase, do either of the following:

- Specify */NOLOWERCASE*.
- Enclose the user name in quotation marks (" "). (See the */USER_NAME* qualifier.)

To send your user name in mixed case, enclose it in quotation marks.

/PROBE_TIMEOUT= seconds

Required if you set */DROP_TIMEOUT*.

Interval, in seconds, that TCP/IP Services checks to see whether your network link and the remote host are still up.

`/TERMINAL_SPEED= baud`

Optional. Default: current speed of your terminal.

Terminal speed in baud rate.

`/TERMINAL_TYPE= type`

Optional. Default: type of physical terminal you are using.

Terminal type. Use this qualifier if the remote host does not recognize your terminal.

`/TRUNCATE_USER_NAME`

`/NOTRUNCATE_USER_NAME`

Optional. Default: `/NOTRUNCATE_USER_NAME`.

Abbreviates the user name sent to the remote host to eight characters. (Required for older UNIX hosts, which limit user names to eight characters.)

`/USER_NAME= remote_user_name`

`-l remote_user_name` (valid only on UNIX systems)

Optional. Default: current name on local host, but in lowercase.

Your user name on the remote host. Specify this qualifier if your user names on the remote host and local host are different.

To send your user name in uppercase, do either of the following:

- Specify `/NOLOWERCASE`.
- Enclose the user name in quotation marks (" ").

To send your user name in mixed case, enclose it in quotation marks.

Examples

1. `$ RLOGIN /USER_NAME="BlissTon" ROLLS`

An OpenVMS user logs in to account `BlissTon` on UNIX host `rolls`. The mixed-case remote user name is enclosed in quotation marks so that `RLOGIN` does not send it all lowercase. This example assumes the user has a proxy account on the remote host.

2. `$ RLOGIN /NOLOWERCASE /USER_NAME=DAVE PLETHORA`

User `DAVE` starts an interactive login session with UNIX host `plethora`. Because this user has an uppercase user name, it is specified with the `/NOLOWERCASE` qualifier. This example assumes the user has a proxy account on the remote host.

3. `$ RLOGIN /ESCAPE_CHARACTER="+" PJARO Return`

Password: (password not echoed) Return

Last login: Fri Aug 21 16:50:40 from world.wide.webber.com

```
Compaq Tru64 System - 4: Tues Aug 25 11:02:20 EST 2003
You have mail.
Tues Aug 25 11:02:20 EST 2002
```

```
pjaro> who Return
```

```
black      tty0    Aug 20 11:02  grades.philosophy.ucd.edu.
bristow    tty1    Aug 12 09:00  grades.biology.ucd.edu.
cutler     tty2    Aug 24 08:55  grades.math.ucd.edu.
```

```
pjaro> pwd Return
```

```
/usr/users/black
```

```
pjaro> ls Return
```

```
bin                Sem1.paper          Sem2.paper
pjaro> +. (characters not echoed)
```

```
%RLOGIN-S-REMCLOSED, Remote connection closed
$
```

OpenVMS user BLACK, with UNIX user name black, logs in to UNIX host pjaro and resets the escape character to a plus sign. By default, TCP/IP Services passes the user name and commands to the remote host in lowercase.

4. \$ **RLOGIN FANTAC Return**

```
OpenVMS Version 7.3 - Unauthorized access is prohibited.
Username: TDERR Return
Password:      (password not echoed) Return
.
.
.
$
```

User TDERR logs in to remote OpenVMS host FANTAC.

5. \$ **RLOGIN QANCE /DROP_TIMEOUT=45**

```
%RLOGIN-E-INETERROR, Internet interface error
-RLOGIN-I-INETCALL, setsockopt(TCP_DROP_IDLE)
-SYSTEM-F-BADPARAM, bad parameter value
$
```

The command fails because the /DROP_TIMEOUT and /PROBE_TIMEOUT qualifiers must both be set.

RSH

RSH — Sends a command to a remote host for execution, including a command that invokes a remote shell script or remote command procedure.

Additional Information

Any command recognized by the remote host is valid. When using the RSH command, consider the following:

- If you omit a command for remote execution, RSH initiates a remote login session (see the RLOGIN command).
- If you specify the /PASSWORD qualifier, with or without a value, RSH executes the REXEC facility (see the /PASSWORD qualifier and the REXEC command).

DCL Syntax

```
RSH host [/EIGHTBIT ] [ remote_command ]
  [ /ESCAPE_CHARACTER=character ]
  [ /LOG_FILE=file ]
  [ /[NO]LOWERCASE ]
  [ /PASSWORD[=password] ]
  [ /[NO]SYSERROR ]
  [ /TERMINAL_SPEED=n ]
  [ /TERMINAL_TYPE=type ]
  [ /TRUNCATE_USER_NAME ]
  [ /USER_NAME=remote_user_name ]
```

UNIX Syntax

```
rsh host [-l remote_user_name ] [ remote_command ]
```

Parameters

host

Required.

Remote host at which you want the command to execute.

remote_command

Optional. Default: none.

Command you are sending to the remote host for execution.

Note

The *remote_command* parameter must be the last item on the command line.

Qualifiers

/EIGHTBIT

Optional. Default: only 7-bit data is sent.

Accepts 8-bit data from the terminal and sends it to the remote system.

/ESCAPE_CHARACTER= *character*

Optional. Default: Tilde (~).

RSH escape character. This character lets you exit the RSH process without entering the remote host's typical logout sequence, such as LOGOUT or Ctrl/D.

Typing the escape character and a period (.) breaks the connection with the remote host. For example:

```
remote> ~. (characters not echoed)
%RSH-S-LCLCLOSED, Local connection closed
local_vms>
```

`/LOG_FILE=file`

Optional. Default: no logging.

Logs a copy of the output to the specified file. Output continues to be directed to SYSS\$OUTPUT while it is being recorded in the log file.

Not valid with /SYSERROR.

`/LOWERCASE`

`/NOLOWERCASE`

Optional. Default: /LOWERCASE.

Sends your local user name to the remote host in lowercase letters.

To send your user name in uppercase letters, do one of the following:

- Specify /NOLOWERCASE.
- Enclose the user name in quotation marks (" "). (See the /USER_NAME qualifier.)

To send your user name in mixed case, enclose it in quotation marks (" ").

`/PASSWORD[=password]`

Optional.

Your password on the remote host.

Invokes the local REXEC facility that directs your RSH command to the REXEC server on the remote host. This server does authentication checking using the user name and password that you specified on the RSH command line.

- Enclose the password in quotation marks (" ") if it is lowercase or mixed case.
- If you omit *password*, RSH (REXEC) prompts you for one.
- Do not use this qualifier if you want to initiate an RLOGIN session.

`/[NO]SYSERROR`

Optional. Default: /NOSYSERROR

Directs diagnostics to SYSS\$ERROR and output to SYSS\$OUTPUT.

When SYSS\$ERROR and SYSS\$OUTPUT both output to the same terminal, the output might be garbled.

/NOSYSERROR directs output only to SYSS\$OUTPUT.

`/TERMINAL_SPEED= n`

Optional. Default: your terminal's current speed.

Terminal speed passed to the remote host during an RLOGIN session.

`/TERMINAL_TYPE= type`

Optional. Default: your terminal's current type.

Terminal type passed to the remote host during an RLOGIN session.

`/TRUNCATE_USER_NAME`

Optional. Default: User names are not truncated

Abbreviates the user name sent to the remote host to eight characters.

`/USER_NAME= remote_user_name`

`-l remote_user_name` (valid only on UNIX systems)

Optional. Default: same name on local host, but in lowercase letters.

Your user name on the remote host. Specify this qualifier if your user names on the remote host and local host are different.

To send your user name in uppercase letters, do one of the following:

- Specify `/NOLOWERCASE`.
- Enclose the user name in quotation marks (" ").

To send your user name in mixed case, enclose it in quotation marks (" ").

Examples

1. `$ RSH HENCE MAN CP`

```
cp(1)
  Name
  cp - copy file data
  Syntax
  cp [ -f ] [ -i ] [ -p ] file1 file2
#
  See Also
  cat(1), pr(1), mv(1)
$
```

A user sends the `man cp` command to UNIX host hence for execution.

2. `$ RSH /USER_NAME=ROGERS DELPHI LS`

OpenVMS user PHILIPS enters the `ls` command for execution at remote UNIX host `delphi`. PHILIPS is accessing an account called `rogers`.

3. `$ RSH /PASSWORD=BLOOMER AVOC8N DIRECTORY`

OpenVMS user PANTO sends the DIRECTORY command to remote OpenVMS host AVOC8N. The remote directory listing is of PANTO's home directory.

RSH /PASSWORD invokes REXEC, which authenticates PANTO's remote password.

4. \$ **RSH /PASSWORD MAGIC CAT BUZZ.TXT**
REXEC password: **(password not echoed) Return**

A user sends the `cat` command to host `magic`. /PASSWORD invokes REXEC, which requires a password. Because the password was omitted from the command line, REXEC prompts the user for it.

Chapter 4. Establishing Network Terminal Sessions Using TELNET/TN3270

With the TELNET software in TCP/IP Services, you can log in to a remote internet system. This is called establishing a TELNET session. Your terminal appears to be attached directly to the remote system.

You can establish a TELNET session with a host that uses IBM 3270 model terminals (TN3270).

Note that you can also use RLOGIN to log in to remote internet hosts. However, RLOGIN does not have the ability to manage a 3270 session. To determine the best remote login service for your needs, see Section 1.1.2. For more information about RLOGIN, see Chapter 3.

The following table lists the TELNET/TN3270 network terminal services and the sections that explain how to use them.

| Capability | Section |
|---|---------------|
| Use either DCL or UNIX command syntax. | 4.1 |
| Establish a network terminal session with any other host that uses TCP/IP as a transport. | 4.3 |
| Log all terminal output to a file. | 4.5 |
| Toggle between the remote host and the local TELNET prompt. | 4.7 |
| Suspend TELNET/TN3270 to spawn a subprocess at the DCL prompt. | 4.8 |
| Establish multiple TELNET sessions. | 4.9 |
| Toggle between open sessions. | 4.9.1 |
| Customize the way TELNET interprets control characters, sends and receives transmissions, and displays processing on your terminal. | 4.6.2 4.10 |
| Send commands to the remote host that affect processing of commands you have entered. | 4.11 |
| Run IBM 3270 model terminal emulation (TN3270). | 4.12 |
| Record a TN3270 screen's contents. | 4.12.5 |

To use the network terminal services, you need the following:

- A user account on the remote host also running TELNET
- A user account on the OpenVMS system that runs TCP/IP Services

To use TELNET, enter the commands summarized in Table 4.1. (For complete command descriptions, see Section 4.13.)

Table 4.1. TELNET/TN3270 Commands Summary

| DCL Style | UNIX Style | Description |
|------------------------------------|---------------------------|---|
| Starting (at the DCL Prompt) | | |
| TELNET | telnet | Invokes TELNET. |
| TELNET <i>remote_host</i> | telnet <i>remote_host</i> | Invokes TELNET and establishes a connection to a remote host. |
| TN3270 | N/A | Invokes TELNET and TN3270. |
| TN3270 <i>remote_host</i> | N/A | Invokes TELNET, runs TN3270, and establishes a connection to a remote host. |
| Getting In and Out of Sessions | | |
| CONNECT | open | Establishes a connection between the local host and a remote host. |
| CREATE_SESSION | N/A | Establishes a pseudo device and connects it to a remote listener port. |
| DELETE_SESSION | N/A | Deletes a pseudo device created by the CREATE_SESSION command. |
| DISCONNECT | close | Terminates your current session. |
| Ctrl/] | Ctrl/] | Takes you from the remote host back to the TELNET prompt. |
| EXIT | quit | Closes open connections and exits from TELNET. |
| HELP | help ? | Invokes online help. |
| RESUME | Return | Resumes an open connection. |
| SPAWN | z | Suspends your TELNET session and takes you to the DCL prompt. |
| Customizing the TELNET Environment | | |
| DISABLE AUTOFLUSH | toggle autoflush | Disables the automatic flushing of output when interrupt characters are sent. |
| DISABLE AUTOSYNCH | toggle autosynch | Disables the automatic sending of interrupt characters in urgent mode. |
| DISABLE BINARY | toggle binary | Disables transmission in binary mode. |
| DISABLE CRLF | toggle crlf | Disables the sending of carriage returns as Return LF. |

| DCL Style | UNIX Style | Description |
|----------------------|-------------------|--|
| DISABLE CRMOD | toggle crmod | Disables the mapping of received carriage returns. |
| DISABLE DEBUG | toggle netdata | Disables the display of data flow information in hexadecimal. |
| DISABLE LOCAL_CHARS | toggle localchars | Disables the interpretation of certain control characters by your local TELNET client and passes them to the remote TELNET server. |
| DISABLE OPTIONS_VIEW | toggle options | Disables the display of option negotiations between the client and server. |
| ENABLE AUTOFLUSH | toggle autoflush | Enables the automatic flushing of output when interrupt characters are sent. |
| ENABLE AUTOSYNCH | toggle autosynch | Enables the automatic sending of interrupt characters in urgent mode. |
| ENABLE BINARY | toggle binary | Enables transmission in binary mode. |
| ENABLE CRLF | toggle crlf | Enables the sending of carriage returns as Return LF. |
| ENABLE CRMOD | toggle crmod | Enables the mapping of received carriage returns. |
| ENABLE DEBUG | toggle netdata | Enables the display of data flow information in hexadecimal. |
| ENABLE LOCAL_CHARS | toggle localchars | Enables the interpretation of certain control characters by your local TELNET client and prohibits them from being passed to the remote TELNET server. |
| ENABLE OPTIONS_VIEW | toggle options | Enables the display of option negotiations between the client and server. |
| SHOW DEVICE | | Displays the current devices. |
| SHOW PARAMETERS | display | Displays the current parameter settings. |
| SHOW SESSION | | Displays the current sessions. |
| SHOW STATUS | status | Displays the current status. |
| SET ECHO | set echo | Sets the echo character to the specified character. |
| SET ERASE | set erase | Sets the erase character to the specified character. |

| DCL Style | UNIX Style | Description |
|-------------------------------------|-----------------|---|
| SET ESCAPE | set escape | Sets the escape character to the specified character. |
| SET FLUSHOUTPUT | set flushoutput | Sets the flush output character to the specified character. |
| SET INTERRUPT | set interrupt | Sets the interrupt character to the specified character. |
| SET KILL | set kill | Sets the kill character to the specified character. |
| SET MODE | mode | Sets the transmission mode to character or line. |
| SET QUIT | set quit | Sets the quit character (an alternate interrupt character) to the specified character. |
| SET TERMINAL | | Sets the terminal type to the specified model. |
| Sending Commands to the Remote Host | | |
| SEND AO | send ao | Sends the Abort Output command. |
| SEND AYT | send ayt | Sends the Are You There command, testing the path to the remote application and eliciting connection status information from the remote host. |
| SEND BRK | send brk | Sends the Break command. |
| SEND EC | send ec | Sends the Erase Character command. |
| SEND EL | send el | Sends the Erase Line command. |
| SEND GA | send ga | Sends the Go Ahead command. |
| SEND IP | send ip | Sends the Interrupt character. |
| SEND NOP | send nop | Sends the No Operation command to test whether data can be sent to the remote host, eliciting an error if the connection is not open. |
| SEND SYNCH | send synch | Sends the Synchronize character. |

4.1. Typing TELNET/TN3270 Commands

Use the following rules when you enter a TELNET command line.

4.1.1. DCL and UNIX Command Formats

With the TELNET command and most of the commands entered at the TELNET prompt, you can use either DCL or UNIX syntax. For example, the following two commands produce the same results:

```
$ TELNET
```

```
TELNET> SHOW PARAMETERS
```

```
$ TELNET
TELNET> DISPLAY
```

4.1.2. Quotation Marks

Do not include quotation marks on the command line, as shown in the following examples:

- The TELNET command line:

```
$ TELNET CENTRAL
```

- The TN3270 command line:

```
$ TN3270 CENTRAL
```

- Commands at the TELNET prompt:

```
TELNET> CONNECT CENTRAL
```

The following example connects to UNIX host `migain` and sets a terminal type with the `/` `TERMINAL_TYPE` qualifier. No quotation marks are needed to pass a terminal type to `migain` in lowercase, as demonstrated with the remote host's `printenv` command.

```
$ TELNET MIGAIN /TERMINAL_TYPE=vt300
%TELNET-I-Trying, Trying ...11.90.208.56
%TELNET-I-SESSION, Session 01, host migain, port 23
-TELNET-I-Escape, Escape character is '^]'
Hello from UNIX host migain
login: root
Password:...
.
.
.
migain# printenv
TERM=vt300
HOME=/
SHELL=/bin/csh
USER=root
PATH=/bin:/usr/bin:/usr/ucb:/etc:/usr/etc:.
LOGNAME=root
PWD=/
migain#
```

4.2. Obtaining Online Help

You can obtain online help for the TELNET and TN3270 services by entering any of the following commands at the DCL prompt:

```
$ HELP TELNET
$ HELP TN3270
$ HELP TCPIP_SERVICES TELNET
```

You can also enter the HELP command at the TELNET prompt:

```
TELNET> HELP
```

4.3. Starting TELNET and TN3270

You can start a TELNET or TN3270 session with a remote host (also called establishing a connection and opening a connection) in one of the following ways:

- At the DCL prompt, enter either the TELNET or the TN3270 command and specify a remote host.
- At the DCL prompt, enter either the TELNET or the TN3270 command with no parameters. At the TELNET or TN3270 prompt that appears, enter the CONNECT or open command, and specify a remote host.
- Invoke and use TELNET or TN3270 from a command procedure (see Section 4.6.1).

The following example shows three ways to establish a connection interactively:

```
$ TELNET CENTRAL /TERMINAL_TYPE=IBM-3278-2
$ TELNET
TELNET> CONNECT CENTRAL 23 VT200
$ TN3270 CENTRAL /TERMINAL_TYPE=IBM-3278-3
```

You can invoke TELNET or TN3270 and, without connecting to a remote host first, enter certain commands that customize the sessions and display parameters or status, as shown in the following example:

```
$ TELNET
TELNET> SHOW STATUS
%TELNET-E-NOSESSION, No active session
Escape character: '^]'
TELNET>SET DEVICE TERMINAL=VT300
TELNET> OPEN GALAXY
%TELNET-I-TRYING, Trying ... 1.20.208.10
%TELNET-I-SESSION, Session 01, host galaxy, port 23
-TELNET-I-ESCAPE, Escape character is ^]
Compaq Tru64 UNIX (galaxy.udb.com) (ttyp5)
login:
```

4.3.1. Establishing Kerberos-Based Secure Connections

Kerberos is a network authentication protocol designed to provide strong authentication for client/server applications by using secret-key cryptography. Kerberos uses strong cryptography so that a client can prove its identity to a server (and vice versa) across an insecure network connection. The TCP/IP TELNET service uses Kerberos to make sure the identity of any user who requests access to a remote host is authentic.

Before you can use the Kerberos TELNET client, the OpenVMS Security Client software must be configured on the OpenVMS system. For more information about installing and configuring the OpenVMS Security Client software, see the *VSI OpenVMS Alpha Version 7.3-2 Upgrade and Installation Manual*.

4.3.1.1. Kerberos Principal Names

Before you use the Kerberos TELNET client, make sure the local host name is fully qualified in the local hosts database. Kerberos realms form principal names using fully-qualified domain names. For example, `terse.mbs.com` is a fully qualified domain name; `terse` is a simple host name.

TCP/IP Services is usually configured so that the host name is entered in the hosts database as a simple host name. That is, on host TERSE, the TCP/IP management command SHOW HOST TERSE returns `terse`, not `terse.mbs.com`.

To correct a mismatch between the Kerberos realm and the TCP/IP Services configurations, follow these steps from a privileged account at a time when system usage is low:

1. Find the host's numeric address. For example:

```
$ TCPIP
TCPIP> SHOW HOST terse
```

```
LOCAL database
```

```
Host address      Host name
15.28.311.11     terse
```

2. Remove the simple host name. For example:

```
TCPIP> SET NOHOST terse/CONFIRM
```

3. Use the SET HOST command to associate the fully qualified domain name with the IP address, as shown in the following example:

```
TCPIP> SET host "terse.mbs.com"/ADDRESS=15.28.311.11 -
_TCPIP> /ALIAS=("TERSE.MBS.COM", "terse", "TERSE")
```

Specify the /ALIAS qualifier to ensure that applications can handle host names in uppercase and lowercase.

4. Confirm that the first name returned is fully qualified.

```
TCPIP> SHOW HOST terse
```

```
LOCAL database
```

```
Host address      Host name
15.28.311.11     terse.mbs.com, TERSE.MBS.COM, terse, TERSE
```

4.3.1.2. Initiating an Authenticated TELNET Connection

To initiate an authenticated connection, perform the following steps:

1. On a Kerberos-enabled system, enter a KINIT *username* command. Enter your password when prompted.

Note

Always specify the user name on the KINIT command line. Kerberos realms are usually set up with lowercase user names, but on OpenVMS, user names are stored in uppercase. When you specify the user name, it will be accepted as lowercase.

2. To initiate an authenticated connection, enter the following command:

```
$ TELNET/AUTHENTICATE host-name
```

3. To use the same ticket on a remote system, you can forward your ticket by entering the following command:

```
$ TELNET/AUTHENTICATE/FORWARD host-name
```

4. To use your credentials in another realm, enter the following command:

```
$ TELNET/AUTHENTICATE/REALM=realm-name.
```

4.4. Exiting TELNET and TN3270

You can end a TELNET or TN3270 session (close the connection) in one of the following ways:

- At the remote host's system prompt, log out.
- At the remote host's system prompt, return to the TELNET or TN3270 prompt and disconnect the session, as follows:
 1. At the remote host's system prompt, press the TELNET/TN3270 escape character (Ctrl/] is the default).
 2. At the TELNET or TN3270 prompt, enter either the DISCONNECT or the `close` command.

The following example shows two ways to close connections:

```
% logout
%TELNET-S-REMCLOSED, Remote connection closed
-TELNET-I-SESSION, Session 01, host galaxy, port 23
TELNET>
TELNET> EXIT
$
%
Ctrl/] (characters not echoed)
TELNET> DISCONNECT
galaxy.udp.com>
TELNET> DISCONNECT
%TELNET-S-LCLCLOSED, Local connection closed
-TELNET-I-SESSION, Session 01, host galaxy, port 23
TELNET>
```

4.5. Keeping a Log of Your TELNET Session

To keep a log of your TELNET session, use the `/LOG_FILE` qualifier. (You cannot use this qualifier with a TN3270 session.)

The following example establishes a TELNET connection to node `central`, sets the terminal type to VT200, and logs all session output to the file `CENT.LOG` in your current directory.

```
$ TELNET/LOG_FILE=CENT.LOG/TERMINAL_TYPE=VT200 CENTRAL
```

4.6. Command Procedures

With DCL command files, you can start TELNET and TN3270 sessions (see Section 4.6.1) and customize the TELNET/TN3270 environment (see Section 4.6.2).

4.6.1. Starting TELNET/TN3270

You can create a command procedure containing the DCL commands DEFINE and TELNET (or TN3270) commands.

The following shows an example of a TELNET command procedure:

```
$! My TELNET startup command file, START_TELNET.COM.  
$!  
$! This command procedure establishes a TELNET session  
$! with UNIX host central.  
$!  
$ DEFINE /USER_MODE SYS$INPUT TT:  
$ TELNET CENTRAL
```

4.6.2. Initialization Command Files

You can create initialization command files to customize your TELNET/TN3270 sessions with SET, ENABLE, and DISABLE commands. These command files:

- Are optional. They eliminate the need to enter individual TELNET commands.
- Have the following requirements:
 - Location: Your login directory
 - Name: TELNETINIT.INI
 - Format: one command per line
- Run automatically when you invoke TELNET or TN3270.
- Let you specify the logical name, TELNETINIT, to point to an initialization file.

The following example shows a TELNET initialization command procedure:

```
! This file, TELNETINIT.INI, sets my TELNET parameters  
! the way I like them.  
!  
DISABLE AUTOFLUSH  
ENABLE BINARY  
ENABLE DEBUG  
SET DEVICE /TERMINAL=VT300  
SET ESCAPE "^p"
```

4.7. Toggling Between the Remote Host and Local TELNET/TN3270

During a session with a remote host, you can toggle between the local TELNET or TN3270 process and the connected host. For example, at the TELNET prompt, you might want to display status, modify a TELNET parameter, or spawn a DCL subprocess.

- To return to the local TELNET or TN3270 prompt (TELNET command mode), enter the TELNET escape sequence (the default is Ctrl/]) at the remote host's prompt (TELNET input mode).

- To resume your session with the remote host, enter one of the following at the TELNET (or TN3270) prompt.

```
TELNET> Return
```

or

```
TELNET> RESUME
```

or

```
TELNET> RESUME n
```

where *n* is the number of the session to which you want to return.

- To change the default escape sequence, enter the following at the TELNET (or TN3270) prompt:

```
TELNET> SET ESCAPE "^escape_character"
```

The following example toggles between remote UNIX host *biway* and the local OpenVMS system.

```
biway> Ctrl/] (characters not echoed)
TELNET> SHOW STATUS
Session 1 Active Host biway Port 23
  Operating Mode: Character-at-a-time
  Escape character: '^]'
  Options:
    Echo - Remote
    Terminal Type - Local
    Terminal Type - VT300
    Suppress Go Ahead - Local
    Suppress Go Ahead - Remote
  Terminal Dataoverruns: 0
  Suspended Network I/Os: 0

.
.
.

TELNET> Return
biway>
```

In the next example, user BENTLEY, working at OpenVMS node EAGLE, uses TELNET to do the following:

1. Establish a connection to UNIX host *fern*.
2. Return to the local TELNET prompt.
3. Display status.
4. Establish a connection to host *gannet*.
5. Return to the TELNET prompt.
6. Display status.
7. Connect to *sands*. But *sands* closes the connection because BENTLEY incorrectly enters the password three times.

8. Try to resume the session with

```
gannet
```

. However, RESUME without specifying a session number fails:

- With multiple sessions, RESUME's default is the "active" session, the one with the most recently opened connection.
- The host to which BENTLEY connected most recently is sands. However, because BENTLEY incorrectly typed the password during login, sands closed the TELNET connection and displayed the following:

```
No current session.
```

- Because no connection is active (or current), BENTLEY must specify a session number on the RESUME command line.

```
$ TELNET FERN
.
.
.
fern> Ctrl/] (characters not echoed)
TELNET> SHOW STATUS
Session 1 Active Host FERN
.
.
.
TELNET> CONNECT GANNET
.
.
.
gannet> Ctrl/] (characters not echoed)
TELNET> SHOW STATUS
Session 2 Active Host GANNET
  Operating Mode: Character-at-a-time
  Escape character: '^]'
.
.
.
Session 1 Waiting Host FERN
TELNET> CONNECT SANDS
%TELNET-I-Trying, Trying...11.18.222.95
%TELNET-I-SESSION, Session 03, host sands, port 23
-TELNET-I-Escape, Escape character is '^]'.
.
.
.
Username: BENTLEY
Password:
User authorization failure
Username: BENTLEY
Password:
User authorization failure
Username: BENTLEY
Password:
User authorization failure
Remote connection closed
```

```
TELNET> RESUME
No current session
TELNET> SHOW STATUS
Session 1 Waiting Host FERN
Session 2 Waiting Host GANNET
.
.
.
TELNET> RESUME 2
gannet> Ctrl/] (characters not echoed)
TELNET> SHOW STATUS
Session 2 Active Host GANNET

    Operating Mode: Character-at-a-time
    Escape character: '^]'
.
.
.
Session 1 Waiting Host FERN
TELNET>
```

4.8. Suspending TELNET to Return to the Local DCL Prompt

While using TELNET, you can use the SPAWN command to suspend your current session and create a subprocess at the local DCL prompt. At the DCL prompt, you can then enter any number of DCL commands. To return to your suspended TELNET session (exiting the DCL subprocess), enter the LOGOUT command.

In the following example, the user suspends the TELNET session to list the files in the working directory on the local host and deletes one of the files in that directory and then returns to the TELNET session.

```
TELNET> SPAWN
$ DIR
.
.
.
$ DEL TR3.TXT:*
$ LOGOUT
Process FERN_1 logged out at 17-JAN-2002 11:08:24.90
TELNET>
```

4.9. Multiple Sessions

TELNET supports:

- Multiple simultaneous connections
- 10 or more simultaneous sessions
- Only one session at a time if it uses TN3270

The TELNET command SHOW STATUS helps you keep track of multiple sessions. The SHOW STATUS display uses the terms shown in Table 4.2.

Table 4.2. Terminology Used in TELNET Command SHOW STATUS Display

| Term | Meaning |
|-----------------|---|
| Active host | Host from which you entered the escape sequence to return to the TELNET prompt. |
| Current session | <p>If you log out of the active host at its system prompt, or enter the TELNET command DISCONNECT, no current session exists.</p> <p>To resume a connection, even if only one exists, enter the following command:</p> <pre>TELNET> RESUME n</pre> |
| Waiting hosts | <p>Other hosts with whom you have open sessions, numbered in the order that you connected to them.</p> <p>To resume a connection with a waiting host, even if only one exists, enter the following command:</p> <pre>TELNET> RESUME n</pre> |

To open another TELNET connection, perform the following steps:

1. At the system prompt of the remote host, enter the TELNET escape sequence (default is Ctrl/]).
2. TELNET returns to the TELNET prompt.
3. Start another session by issuing the CONNECT command.

The following example starts multiple sessions with UNIX hosts `finder` and `keeper`.

```
$ TELNET FINDER
.
.
.
finder> ( )
.
.
.
finder> Ctrl/]      (characters not echoed)
TELNET> CONNECT KEEPER
.
.
.
keeper> ( )
.
.
.
keeper> Ctrl/]      (characters not echoed)
TELNET> ( )
```

4.9.1. Toggling Between Open Sessions

To toggle between one open TELNET connection and another:

1. Enter the TELNET escape sequence.
2. If necessary, use the SHOW STATUS command to check the number of your session with the other host.
3. Enter the TELNET RESUME *n* command, where *n* is the number of the session to which you want to return.

For an example, see Section 4.7.

4.9.2. Displaying Session Information

To display a list of your active sessions, use the following SHOW SESSION command:

```
TELNET> SHOW SESSION Return
Session 01, host finder, port 23
Session 02, host keeper, port 23 (default active session)
```

If there are no active connections, the SHOW SESSION command displays the following message:

```
%TELNET-E-NOSESSION, No active session
```

4.10. Customizing TELNET/TN3270 Transmissions, Control Characters, and Displays

To customize the TELNET/TN3270 processing environment, use the ENABLE, DISABLE, and SET commands. You can modify how TELNET and TN3270 perform the following actions:

- Send and receive transmissions
- Display processing on your terminal
- Interpret certain control characters

You can redefine the following control characters, in situations when, for example, your terminal or the remote host does not recognize the corresponding default control character.

- Echo
- Erase
- Escape
- Flush output
- Interrupt
- Kill
- Quit

Use the SET command to redefine these characters. For example, the following command defines the interrupt character to be the letter a or A.

```
TELNET> SET INTERRUPT "^a"
```

TN3270 allows you to redefine your keyboard. You can redefine most IBM 3270 model functions and all emulated functions and characters. You can create a key definition file with DEFINE/KEY statements to redefine the keyboard. Alternatively, you can redefine a key interactively by using the DEF KEY function (Ctrl/K on VT100-and VT200-series terminals) (see Section 4.12.9.)

You can determine the mode TELNET uses to transmit data. The appropriate TELNET mode for a session depends on:

- The remote host to which you are connecting
- The applications you use

Table 4.3 shows the modes that control TELNET communications.

Table 4.3. TELNET Transmission Modes

| Mode | Function |
|-----------------------------|--|
| Local Characters Mode | The local host interprets control characters, translating them to TELNET protocol sequences (ENABLE LOCAL_CHARS). Use this mode when the local and remote hosts implement different control characters. By default, characters are interpreted by the remote host (DISABLE LOCAL_CHARS). |
| Binary Mode | The local host sends transmissions in binary mode (ENABLE BINARY). Use this mode when the remote host expects each line of data to end with a carriage return/line feed combination. By default, the local host sends transmissions with the end-of-line (EOL) character mapped to the carriage return/line feed combination (DISABLE BINARY). |
| Debug Mode | TELNET displays data flow in both hexadecimal and readable text (ENABLE DEBUG). By default, TELNET displays data in readable text only (DISABLE DEBUG). |
| Character Transmission Mode | TELNET transmits data one character at a time (SET MODE CHAR) rather than line by line. Use this mode when you run a text editor (on the remote host) that does character processing. Character transmission mode is the default. |
| Line Transmission Mode | TELNET transmits data one line at a time (SET MODE LINE). Most clients send a character at a time. The remote host server must support line transmission mode. This allows you to do signal trapping as well as local-character editing and tab expansion. |

4.11. Sending Commands to the Connected Remote Host

While in input mode (an active session with a remote host), you can enter SEND commands that affect the remote host's processing of commands you have entered. You use these commands when the remote host does not recognize the default key or key sequence used for the same operation. You can use the SEND AYT and SEND NOP commands to determine whether or not your session with the remote host is still open. Table 4.4 lists the functions available to you at the remote host with each SEND command.

Table 4.4. Sending Commands to the Remote Host

| Function | Command | When to Use |
|---|------------|---|
| Abort output of the last remote command you entered, without discontinuing execution of the process. | SEND AO | You want to terminate output but not the execution of the process. After already aborting output, you want to resume output. The remote host does not recognize the Ctrl/O sequence as the flush output character. |
| Determine if your connection with the remote host is still established. The remote host replies with connection status information. | SEND AYT | Test the connection to the remote host application and verify that the remote host application is responding. You are notified on success. |
| Terminate execution of the last command you entered at the remote host. | SEND BRK | The remote host does not recognize the Ctrl/C sequence as an interrupt character. |
| Delete the last character you entered at the remote host. | SEND EC | The remote host does not recognize your Delete key. |
| Delete the last line of text you entered at the remote host. | SEND EL | The remote host does not recognize your Delete key or command-line recall. |
| Signal the remote host that your local system is ready. | SEND GA | The application requires GA commands in either one or both directions. |
| Interrupt execution of the last command you entered at the remote host. | SEND IP | Your terminal or the remote host does not recognize the default interrupt character (Ctrl/C). |
| Determine whether your local host can send data to the connected remote host and whether the remote host can receive that data. | SEND NOP | Check the communication path to the remote host. You are notified on error. |
| Interrupt the current process you are executing at the remote host, and in urgent mode (out- | SEND SYNCH | You want to clear immediately the communications path between your system and the remote host, with the remote |

| Function | Command | When to Use |
|---|---------|--|
| of-band), get a quicker response time to the interrupt. | | host ignoring any incoming data not yet processed. |

4.12. IBM 3270 Model Terminal Emulation (TN3270)

You can run a TELNET session with a host that uses IBM 3270 model terminals by using the TN3270 command. The TN3270 command:

- Provides IBM 3270 Information Display System (IDS) terminal emulation.
- Assigns IBM 3270 functions to your keyboard.
- Assigns IDS functions to specific keys.

During a TN3270 session, you can do the following:

- Record your sessions (Section 4.12.5).
- Redefine keys permanently (Section 4.12.9.5).
- Redefine keys interactively (Section 4.12.9.5.1).
- Troubleshoot problems (Section 4.12.9.6).

Note

When you run TN3270, you can only have one session. You cannot have other sessions running simultaneously, as you can when running normal TELNET sessions.

4.12.1. Supported IBM Terminal Models

Table 4.5 lists the IBM 3270 terminal models that TELNET/TN3270 can emulate.

Table 4.5. TELNET — IBM 3270 Model Terminals Supported for Telnet/TN3270

| Model | Screen Size (Rows x Columns) |
|------------------|------------------------------|
| IBM 3278 Model 2 | 24 x 80 |
| IBM 3278 Model 3 | 32 x 80 |
| IBM 3278 Model 4 | 43 x 80 |
| IBM 3278 Model 5 | 27 x 132 |

4.12.2. Setting Up Your PC or Terminal for IBM 3270 Terminal Emulation

When you use TELNET and specify IBM 3270 model terminal emulation (TN3270), the image displayed on your screen depends on the following criteria:

- The type of terminal that you are using or that your PC is emulating

- The features you set on it

Sections 4.12.2.1 and 4.12.2.2 explain how to set up VT200- and VT100-series terminals (or emulation on PCs), respectively.

4.12.2.1. VT200-Series Terminal Setup

To set up a VT200-Series terminal for emulation, follow these steps:

1. At the Set-up Directory menu, select the keyboard type that corresponds to the keyboard layout you are using (for example, North American).
2. At the Display Set-up menu, select the following:
 - Interpret controls
 - Light text, dark screen
 - Cursor (visible)
3. At the General Set-up menu, select the following:
 - VT200 or VT100 mode (if VT100 mode, set VT100 ID)
 - 7-bit or 8-bit controls
 - Multinational/national
 - Normal cursor keys
 - No new line
4. At the Communications Set-up menu, select the following:
 - XOFF at 64 or XOFF at 128
 - 8-bit communication line
 - 8-bit (any) parity
 - No local echo
5. At the Keyboard Set-up menu, select warning bell ON.

At the DCL prompt, enter the following command:

```
$ SET TERMINAL /INQUIRE
```

The software determines the terminal's characteristics and sets the appropriate parameters.

If you select National character mode, enter the following command:

```
$ SET TERMINAL /NOEIGHTBIT
```

4.12.2.2. VT100-Series Terminal Setup

To set up a VT100-Series terminal for emulation, follow these steps:

1. Set your terminal to ANSI mode (see the user's guide for your terminal).
2. Enter the following command at the DCL prompt:

```
$ SET TERMINAL/INQUIRE
```

This command causes the terminal to be questioned about its characteristics. The appropriate parameters for the terminal are set up according to its response.

TN3270 requires terminal windows that support at least 24 lines and 80 columns.

4.12.3. Starting and Exiting from TN3270

Start a TN3270 session by using the TN3270 command. You can also use the TELNET/TN3270 `TERMINAL_TYPE=IBM-3278-n` command. The default terminal type is IBM-3278-2. The following examples show several ways to start a TN3270 session, using the TN3270 command and connecting to host CENTRAL. For more information, see Section 4.3.

- To use the default terminal type:

```
$ TN3270 CENTRAL
```

- To use a terminal type other than the default:

```
$ TN3270/TERMINAL_TYPE=IBM-3278-4 CENTRAL
```

You can invoke TN3270 and, without first connecting to a remote host, enter certain commands that customize the sessions and display parameters or status. You can also use a command file to invoke TN3270 and the customization.

The TN3270 command includes several qualifiers that allow you to specify customized or special files for the following:

- Character-set translation tables file (`/CHARACTER_SET=file`) that translates between EBCDIC and the DMCS. The default file, if set up by your system manager, is `SYS$LIBRARY:TN3270DEF.TBL`. If this file does not exist, and you do not specify a file, TN3270 uses its own translation table.
- Keyboard definition file (`/KEY_DEFINITIONS=file`) that you create as an alternative to the default keyboard layout.
- National Replacement Character Set (NRCS) file (`/NATIONAL_CHARACTERS=n`) for which your terminal is configured. The default for 8-bit terminals is `MULTINATIONAL`. The default for 7-bit terminals is `US_ASCII`.

You can end a TN3270 session (close the connection) in one of the following ways:

- At the remote host's system prompt, log out.
- At the remote host's system prompt, return to the TN3270 prompt and disconnect the session as follows:
 1. At the remote host's system prompt, press the TN3270 escape character (Ctrl/] is the default).
 2. At the TN3270 prompt, enter either the `DISCONNECT` or the `close` command.

4.12.4. Clearing Error Messages

TN3270 displays error messages in a bordered display at the bottom of your screen. This display overwrites the status display and remains visible until you clear it. To clear the display, invoke one of the following functions:

- REFR
- HELP
- SET FIL
- DEF KEY

4.12.5. Recording Sessions

During a TN3270 session, you can record your screen's contents. The PRINT function directs your screen's contents to either a file or a spooled printer.

To record your screen's contents, follow these steps:

1. Invoke the PRINT keyboard function, as described in Section 4.12.8.

The screen display is recorded in a file in a compressed state. Null lines (lines with only nulls and attribute characters) do not appear.

2. Invoke the ENTER function or any function that transmits the screen contents to the remote host's application, as described in Section 4.12.8.

This creates the default output file, TN3270PRINT.LIS. TELNET does the following:

- Each time you start a TELNET session that runs TN3270, TELNET opens a new TN3270PRINT.LIS file.
- Each time you use PRINT during a session, TELNET appends new output from the screen to the end of TN3270PRINT.LIS.
- Each time you use PRINT, if you direct the output to a printer, TELNET creates a separate entry in the print queue.
- If the printer is spooled, TELNET immediately prints the output.

You can specify a different file name. To change the name, use one of the following methods:

- When you start a TN3270 session, use the /PRINTER qualifier, as shown in the following example:

```
$ TN3270 [ host ] /PRINTER=file
```

- During a TN3270 session, follow these steps:
 1. Use the SET FIL keyboard function, as explained in Section 4.12.8.
 2. At the prompt for a new file name, enter a name.

If you specify the same name that is already in use, subsequent PRINT operations direct output to a new version of the same file.

3. Use the NEW LINE keyboard function, as explained in Section 4.12.8.

4.12.6. Online Help

Online help during a TN3270 session displays the following information:

- A picture of the keypad
- A list of TN3270 keyboard functions
- The key combinations that invoke the TN3270 keyboard functions

The Help screen shows the TN3270 functions as they correspond to the keys on your physical keyboard, as follows:

- Top-row keys
- Editing keypad
- Application keypad
- Up to 32 control or extended character definitions
- All your definitions and changes, including those you make interactively

To see the Help screen, use the HELP function key F15.

4.12.7. If the Keyboard Locks

If your keyboard locks, the terminal bell rings, and the status line displays the following information:

Inhib

To unlock the keyboard, press the KP0 key to invoke the RESET function. (KP0 refers to the zero (0) key in the application keypad on the right hand side of the keyboard.)

Do not use the following functions when the cursor is in a protected field (a field that does not accept user input):

- DELETE
- DUP
- ER EOF
- FM
- Any graphic character

4.12.8. Keyboard Functions

This section describes the keyboard functions. Preceding each function description are the key sequences for VT100 and VT200 terminals and the function name to use in a DEFINE/KEY command. In many of the key sequences, TN3270 allows use of the extended function (EXT) feature.

Used in conjunction with another key, EXT allows access to an extended function for that key. The following illustrates the extended function feature in more detail.

ATTACH

| | |
|-----------------------------|-------------------|
| VT100: EXT + E | VT200: EXT + Find |
| DEFINE_KEY Function: ATTACH | |

Changes control from one subprocess to another subprocess or to the parent process. When you invoke the ATTACH function, TN3270 uses the name of the last process to which you attached as the default process name.

If you want to attach to a different process, press Ctrl/U to erase the default process name. You can then enter the process name of your choice at the prompt. The process name can be a quoted string. Use the quotation marks to preserve spaces, tabs, or lowercase letters in strings.

ATTN

| | |
|--------------------------------|------------|
| VT100: EXT + A | VT200: F19 |
| DEFINE_KEY Function: ATTENTION | |

Provides a way to "get the attention of" the remote application program that you are running by sending a SIGNAL RU command to the remote host. See the user's guide of the particular application program to learn what response the program gives when you use this key.

Back Tab (| Left arrow)

| | |
|-------------------------------|------------|
| VT100: BACKSPACE | VT200: F12 |
| DEFINE_KEY Function: BACK_TAB | |

Moves the cursor, depending on the type of screen. On a formatted screen, the cursor moves one of the following ways, depending on the cursor's location when you press this key:

- If the cursor is in a field, but not at the first position of the field, it moves to the beginning of the unprotected field that it is in.
- If the cursor is in the first position of a field, it moves to the beginning of the preceding unprotected field. If the cursor is in the first position of the first unprotected field, the cursor moves to the first position of the last unprotected field on the screen.

On an unformatted screen, the cursor returns to the first position on the screen.

Cent Sign (¢)

| | |
|-----------------------------|----------------|
| VT100: EXT + C | VT200: EXT + C |
| DEFINE_KEY Function: (None) | |

Enters a cent sign. If your terminal does not have this character, your screen displays a hyphen (-).

CLEAR

| | |
|--------------------|------------------|
| VT100: EXT + Enter | VT200: EXT + F20 |
|--------------------|------------------|

| |
|----------------------------|
| DEFINE_KEY Function: CLEAR |
|----------------------------|

Clears the screen and moves the cursor to the first position on the screen. When you invoke the CLEAR function, the software notifies the application program that this function has been used.

DEF KEY (DEFINE key)

| | |
|---------------------------------|---------------|
| VT100: Ctrl/K | VT200: Ctrl/K |
| DEFINE_KEY Function: DEFINE_KEY | |

Lets you interactively define or redefine a key. You get a prompt for the name of the key to define and for a function you want to assign to that key. Refer to Section 4.12.9 for more information about using the DEF KEY function.

DELETE

| | |
|-----------------------------|------------|
| VT100: Delete | VT200: <X] |
| DEFINE_KEY Function: DELETE | |

Deletes the character at the cursor. The cursor remains where it is, and the other characters to the right of the cursor in the same field move one position to the left. The end of the field fills with blanks. Note that this is not the action normally associated with the Delete key on keyboards.

DSP ATT (display attributes)

| | |
|---|------------------|
| VT100: Ctrl/V | VT200: EXT + F17 |
| DEFINE_KEY Function: DISPLAY_ATTRIBUTES | |

Enables and disables the visible attribute mode. This mode of operation forces display of the attribute characters (that is, the characters at the start of a field that indicate the display and data type of that field). In IBM 3270 model terminal emulation (TN3270), you can use the DSP ATT function to debug application programs, as explained in Section 4.12.10.

DUP (duplicate)

| | |
|--------------------------|------------------|
| VT100: EXT + * | VT200: EXT + F12 |
| DEFINE_KEY Function: DUP | |

Lets you enter a value in the same field in several forms without needing to repeat the entry for each form.

After entering the data in the field on the first form, use the DUP function when at the same field on succeeding forms. The application program makes the necessary translation, filling in these fields with the same value. For details about the use of this key, refer to the user's guide of the particular application program.

Displays an asterisk (*).

DV CNCL (device cancel)

| | |
|----------------|---------------------|
| VT100: EXT + U | VT200: EXT + Remove |
|----------------|---------------------|

| |
|-----------------------------|
| DEFINE_KEY Function: DVCNCL |
|-----------------------------|

Cancels the RECORD function. Use the DV CNCL function if you begin using the RECORD function and then decide you want to stop. If you want to delete a sequence that has already been recorded on a PF key, use the RECORD function, press the PF key, and then use the DV CNCL function.

ENTER

| | |
|----------------------------|-------------------|
| VT100: Line Feed + Enter | VT200: Do + Enter |
| DEFINE_KEY Function: ENTER | |

Sends your input to the remote application program. While this communication is active, the keyboard locks and indicator `Inhib` appears on the status line. Usually the application program releases the keyboard when it has finished processing your input.

ER EOF (erase to the end of the field)

| | |
|--------------------------------|------------|
| VT100: EXT + KP, | VT200: F18 |
| DEFINE_KEY Function: ERASE_EOF | |

Erases the contents of the current field, from the location of the cursor to the end of the field. The cursor remains in the same location.

ER INP (erase input)

| | |
|----------------------------------|------------------|
| VT100: EXT + KP- | VT200: EXT + F18 |
| DEFINE_KEY Function: ERASE_INPUT | |

On a formatted screen, clears all the data in the unprotected fields on your screen and moves the cursor to the first position in the first unprotected field on the screen.

On an unformatted screen, clears all the data and moves the cursor to the first position on the screen.

You can also use the ER INP function to remove all previously recorded key sequences by using the RECORD function and then the ER INP function.

EXIT

| | |
|---------------------------|----------------------|
| VT100: Ctrl/Z or F10 | VT200: Ctrl/Z or F10 |
| DEFINE_KEY Function: EXIT | |

Terminates the remote TELNET/TN3270 session. Aborts any exchange of data in progress between the local and remote hosts. Note that terminating a session with the IBM host in this way may result in improper termination of the session. For the appropriate log-off command string, see the user's guide for the IBM application with which you are communicating.

EXT (extended function)

| | |
|------------|------------|
| VT100: KP. | VT200: KP. |
|------------|------------|

| |
|-----------------------------|
| DEFINE_KEY Function: EXTEND |
|-----------------------------|

Used in conjunction with another key, allows access to an extended function for that key. First invoke the EXT function, and then press the second key. If you invoke EXT accidentally, invoke the RESET function to cancel the EXT function.

If the status display is enabled when you invoke the EXT function, the word `Extend` appears on the status line.

FM (field mark)

| | |
|-------------------------|------------------|
| VT100: EXT + ; | VT200: EXT + F13 |
| DEFINE_KEY Function: FM | |

Specifies the end of a field on an unformatted screen or the end of part of an unprotected field on a formatted screen. Refer to the user's guide of the remote application program for specific use of this key.

Displays a semicolon (;).

HELP

| | |
|---------------------------|-------------|
| VT100: EXT + H | VT200: Help |
| DEFINE_KEY Function: HELP | |

Displays online help and an illustration of the TN3270 keyboard.

HOME

| | |
|---------------------------|------------|
| VT100: EXT + B | VT200: F13 |
| DEFINE_KEY Function: HOME | |

Repositions the cursor to the first position in the first unprotected field on the screen (that is, to the beginning of the input area on the screen).

Horizontal Control (Right arrow and Left arrow)

| | |
|--|----------------------------------|
| VT100: Right arrow or Left arrow | VT200: Right arrow or Left arrow |
| DEFINE_KEY Function: RIGHT, RIGHT_NOWRAP, LEFT, or LEFT_NOWRAP | |

Moves the cursor horizontally across your screen without changing data you have already entered. Note the following about cursor behavior:

- If the cursor is at the end of a line when you use the Right arrow function, the cursor moves to the start of the next line.
- If the cursor is at the beginning of a line when you use the Left arrow function, the cursor moves to the end of the previous line.

If the screen display you receive is wider than 80 columns, you can use the Right arrow and Left arrow functions to move through the display.

If you want the cursor to wrap to the opposite edge of the display, use one of the following function sequences:

EXT + Right arrow

EXT + Left arrow

INSERT

| | |
|----------------------------------|------------|
| VT100: EXT + PF4 | VT200: F14 |
| DEFINE_KEY Function: INSERT_MODE | |

Enables insert mode. Use insert mode to edit what you entered. If the status display is enabled, the word `Insert` appears.

In insert mode, when you enter a character into an unprotected field, it is displayed to the left of the cursor, moving the following display elements one position to the right:

- The cursor
- The character at the cursor location
- All the characters to the right of the cursor in the field

You can insert characters into following:

- An unformatted screen
- An unprotected field on a formatted screen until it is full

If you attempt to insert characters after the field is full, the keyboard locks, the terminal bell rings, and the word `Inhib` appears on the status line. If the keyboard locks when you try to insert characters into a field that looks empty, the field might have trailing spaces. To delete these spaces, use the ER EOF function.

To return your screen to the normal mode of entry, use one of the following keyboard functions:

- RESET
- CLEAR
- ENTER
- Any PA key
- Any PF key

Logical NOT (|−)

| | |
|-----------------------------|----------------|
| VT100: EXT + N | VT200: EXT + N |
| DEFINE_KEY Function: (None) | |

Represents the remote host's symbol for a logical NOT; displayed as a circumflex (^).

Logical OR (|)

| | |
|-----------------------------|----------------|
| VT100: EXT + O | VT200: EXT + O |
| DEFINE_KEY Function: (None) | |

Represents the remote host's symbol for a logical OR; displayed as a solid vertical line from the terminal's graphics set. Press Ext + O if the vertical bar is not available on your keyboard.

New Line (hooked left arrow)

| | |
|------------------------------|---------------|
| VT100: Return | VT200: Return |
| DEFINE_KEY Function: NEWLINE | |

Moves the cursor to the first unprotected position on the next line of your screen. If no unprotected fields are on the screen when you invoke the new line function, the cursor moves to the first location on the screen. If the screen has no fields, this key has the same function as the Return key.

NUM OVR (numeric lock override)

| | |
|-----------------------------|---------------|
| VT100: EXT + J | VT200: Remove |
| DEFINE_KEY Function: NUMOVR | |

Lets you enter nonnumeric characters into numeric fields. Once you enable this function, use NUM OVR again to disable it. If you do not disable the numeric lock override, it remains enabled even after you exit from TN3270. The letter O appears on the status line to indicate that the numeric lock override is in effect.

PA1, PA2, PA3

| | |
|------------------------------|------------------------|
| VT100: PF4 , KP- , KP, | VT200: PF4 , KP- , KP, |
| DEFINE_KEY Function: PA1–PA3 | |

These program access keys are defined by the program you are using. These keys request attention from the remote application program without sending any data. You should refer to the user's guide of your application program to learn how the PA keys are defined.

PF1 through PF24

| | |
|-------------------------------|------------------|
| VT100: see table | VT200: see table |
| DEFINE_KEY Function: PF1–PF24 | |

These program function keys are defined by the remote application program you are using. They request attention from the application program and send the data entered to the host. The PF keys are coded by the application program to perform functions relating to the application. A particular PF key may be coded differently from one application to another. The user's guide of the remote application program usually defines the specific PF key assignments for that application program.

| To Implement this Function | Press This Key or Key Combination |
|----------------------------|-----------------------------------|
| PF1 | PF1 |

| To Implement this Function | Press This Key or Key Combination |
|----------------------------|-----------------------------------|
| PF2 | PF2 |
| PF3 | PF3 |
| PF4 | KP7 |
| PF5 | KP8 |
| PF6 | KP9 |
| PF7 | KP4 |
| PF8 | KP5 |
| PF9 | KP6 |
| PF10 | KP1 |
| PF11 | KP2 |
| PF12 | KP3 |
| PF13 | EXT + PF1 |
| PF14 | EXT + PF2 |
| PF15 | EXT + PF3 |
| PF16 | EXT + KP7 |
| PF17 | EXT + KP8 |
| PF18 | EXT + KP9 |
| PF19 | EXT + KP4 |
| PF20 | EXT + KP5 |
| PF21 | EXT + KP6 |
| PF22 | EXT + KP1 |
| PF23 | EXT + KP2 |
| PF24 | EXT + KP3 |

PLAY

| | |
|---------------------------|--------------------|
| VT100: EXT + M | VT200: Insert Here |
| DEFINE_KEY Function: PLAY | |

Recalls keystroke sequences stored on PF keys using the RECORD function. Invoke the PLAY function and then press the PF key on which the desired key sequence is stored. The PLAY function executes all commands included in the keystroke sequence.

If the HELP utility is invoked in your key sequence, the PLAY function continues until you exit from the HELP utility. Also, if you use functions that require you to respond to prompts (such as ATTACH, DEF KEY, SET FIL, or SPAWN), the information you enter at the prompt is not recorded. When you recall the sequence, the system prompts you for this information again.

The letter P appears on the status line if the status display is enabled.

PRINT

| | |
|----------------|------------|
| VT100: EXT + P | VT200: F11 |
|----------------|------------|

| |
|----------------------------|
| DEFINE_KEY Function: PRINT |
|----------------------------|

Records the contents of your screen in a file or at a printer. (This is a local print feature.) If the status display is enabled when you use the PRINT function, the word `Print` appears on the status line. Your screen refreshes when the printing process completes.

The first use of PRINT in a given run of TN3270 creates a new version of the output file. Successive uses of PRINT in the same program cause the screen contents to append to the existing file. If the output is directed to a printer, each use of PRINT creates a separate entry in the printer queue. If the printer is a spooled printer, the output is released for printing immediately.

To specify where to direct the output file, use the command qualifier `/PRINTER= file`. The SET FIL function allows you to change the name of the output file each time you invoke the PRINT function.

RECORD

| | |
|-----------------------------|--------------------------|
| VT100: EXT + L | VT200: EXT + Insert Here |
| DEFINE_KEY Function: RECORD | |

Saves a keystroke sequence on a specific PF key. Invoke the RECORD function with the appropriate key sequence, press the PF key as prompted, enter the keystroke sequence, and then invoke the RECORD function again. You can save a maximum number of 127 keystrokes on each PF key. If the status display is enabled when you use the RECORD function, the letter `R` appears on the status line.

To recall the keystroke sequence, use the PLAY function. To cancel the RECORD function, use the DV CNCL function. To erase all previously recorded key sequences, use the ER INP function.

REFR (refresh)

| | |
|------------------------------|----------------------|
| VT100: Ctrl/W | VT200: Ctrl/W or F20 |
| DEFINE_KEY Function: REFRESH | |

Removes TN3270 error messages, operating system messages, or other messages that appear on your screen. This key function deletes extraneous characters from your screen and redisplay the fields and data that were on the screen before the interruption.

This function does not transmit or receive data from the remote host. It is a local OpenVMS function.

RESET

| | |
|----------------------------|------------|
| VT100: KP0 | VT200: KP0 |
| DEFINE_KEY Function: RESET | |

Returns the keyboard to normal input mode from insert mode. Also, the RESET function returns the keyboard to your control after it locks when you try to enter data in to a protected or a full field, or when you try to enter the wrong type of data in a field.

Invoking RESET turns off the `Inhib` indicator. The cursor remains where it is and the screen remains unchanged.

SELECT

| | |
|----------------|---------------|
| VT100: EXT + K | VT200: Select |
|----------------|---------------|

| |
|-----------------------------|
| DEFINE_KEY Function: SELECT |
|-----------------------------|

Lets you choose items from a menu, table, or list and then notify the program of your selection. Use the arrow keys to position the cursor on the field designator character, then use the SELECT function. For more information on using SELECT, refer to the user's guide of the remote application.

SET FIL (set print file)

| | |
|------------------------------------|------------------|
| VT100: EXT + F or Ctrl/F | VT200: EXT + F11 |
| DEFINE_KEY Function: SET_PRINTFILE | |

Lets you change the name of the file or device that receives output each time you invoke the PRINT function. After you invoke SET FIL, you are prompted for the name of a new output device, emulating the remote host's IDENT function.

Note that if you specify the same name that is already in use, subsequent PRINT operations direct output to a new version of the same file.

SHO MSG

| | |
|-----------------------------------|------------------|
| VT100: EXT + G | VT200: EXT + F14 |
| DEFINE_KEY Function: SHOW_MESSAGE | |

Displays the broadcast messages that have been posted on a separate screen. If the status line is enabled, the indicator MSG appears on the status line. If you do not read the messages before they fill up the screen, the messages begin to scroll up out of view and you can no longer read them. These broadcast messages are not saved after you either read them or exit TN3270.

SPAWN

| | |
|----------------------------|-------------|
| VT100: EXT + D | VT200: Find |
| DEFINE_KEY Function: SPAWN | |

Creates a subprocess under the current process. Use the LOGOUT command to terminate the subprocess. Because a tree of subprocesses can be established using the SPAWN function, you must be careful when terminating any process in the tree. When a process is terminated, all subprocesses below that point in the tree are terminated automatically.

When you create a subprocess, you can specify an optional command string. The command string is executed within the created subprocess, and the subprocess terminates upon completion of the command.

STATUS

| | |
|-----------------------------|------------|
| VT100: EXT + S | VT200: F17 |
| DEFINE_KEY Function: STATUS | |

Lets you enable and disable the display of status information.

When you enable STATUS, the last line on your screen is painted over with a reverse video strip. This line may conceal remote host system or application information. If this occurs, the word Hidden appears in the status line.

You can disable the status display by using the STATUS function again.

SYS REQ (system request)

| | |
|----------------------------------|------------------|
| VT100: EXT + R | VT200: EXT + F19 |
| DEFINE_KEY Function: SYS_REQUEST | |

Lets you shift between the application program (the LU-LU session) and the control program (the SSCP-LU session). If the status display is enabled, the App1 or SSCP indicator appears on the status line to indicate the type of session. App1 appears when you are in an LU-LU session, and SSCP appears when you are in the SSCP-LU session.

The screen is refreshed when you use the SYS REQ function.

Tab (Right arrow |)

| | |
|--------------------------|------------|
| VT100: Tab | VT200: Tab |
| DEFINE_KEY Function: TAB | |

Moves the cursor to the first character location of the next unprotected field on your screen. If the screen has no fields, the Right arrow function moves the cursor to the first location on the screen.

If the cursor is within the last unprotected field on the screen, the cursor moves to the first position of the first unprotected field on the screen.

Vertical Control (Up arrow and Down arrow)

| | |
|--|-------------------------------|
| VT100: Up arrow or Down arrow | VT200: Up arrow or Down arrow |
| DEFINE_KEY Function: UP, UP_NOWRAP, DOWN, or DOWN_NOWRAP | |

Moves the cursor vertically on your screen without altering the data you have already entered. Note the following about the cursor behavior:

- If the cursor is at the top of the screen when you press the Up arrow, the cursor appears in the same column at the bottom of the screen.
- If the cursor is at the bottom of the screen when you press the Down arrow, the cursor appears in the same column at the top of the screen

If the screen display you receive is larger than 24 rows deep, you can use the Up arrow and the Down arrow keys to move through the display. These keys scroll the screen display up or down.

If you want the cursor to wrap to the opposite edge of the display, use the key sequence EXT + Up arrow or EXT + Down arrow.

4.12.8.1. Associated Documentation

For additional information about TN3270 key functions, see the following IBM documents:

- *IBM 3270 Information Display System*
- *IBM 3270 Information Display System: Operator's Guide*

- *IBM 3270 Information Display System: 3278 Display Station Operator's Guide*

4.12.9. Redefining Your Keyboard

You can reassign functions and keys.

4.12.9.1. Functions You Can Redefine

You can redefine the following functions:

- All emulated functions
- Most IBM 3270 model functions
- All emulated alphanumeric and graphic characters

4.12.9.2. Keys You Can Define

The keys you can define are listed in Table 4.6.

Table 4.6. Definable Keys for TN3270

| Type of Key | Key Name |
|--|---|
| Function keys (VT100 and VT200) | PF1 through PF4 |
| Application keys (VT100 and VT200) | KP0 through KP9 ENTER MINUS COMMA PERIOD |
| Top-row function keys (VT200) | F6 through F20 HELP (F15) DO (F16) |
| Editing keypad (E1 through E6) (VT200) | FIND (E1) INSERT_HERE (E2) REMOVE (E3) SELECT (E4) PREV_SCREEN (E5) NEXT_SCREEN (E6) |
| Cursor keys (VT100 and VT200) | UP DOWN |

| Type of Key | Key Name |
|--------------------------------|---|
| | LEFT |
| | RIGHT |
| Control keys (VT100 and VT200) | Ctrl/A through Ctrl/Z, including: Ctrl/H (BS) Ctrl/I (HT) Ctrl/J (LF) Ctrl/M (CR) Excluding: Ctrl/Y – Interrupt Ctrl/C – Cancel/interrupt Ctrl/O – Output off/on Ctrl/S – Suspend output Ctrl/Q – Resume output |

4.12.9.3. Keys You Cannot Define

You cannot redefine the following reserved keys:

- Ctrl/Y – Interrupt
- Ctrl/C – Cancel/interrupt
- Ctrl/O – Output off/on
- Ctrl/S – Suspend output
- Ctrl/Q – Resume output
- F1–F5

4.12.9.4. Redefining Keys

To redefine a keyboard key, use either of the following methods:

- Create a key definition file. This is a text file with individual key definitions in the form of DEFINE/KEY statements and DELETE/KEY statements (see Section 4.12.9.5).
- Use the DEF KEY function (see Section 4.12.9.5.1).

The following example establishes a TELNET/TN3270 connection to host JUNCO. By default, the terminal functions as if it were an IBM-3278-2 model terminal. It uses your customized keyboard definition file NEW_KEYS.DAT.

```
$ TN3270 JUNCO /KEY_DEFINITION=NEW_KEYS.DAT
```

4.12.9.5. Creating a Key Definition File

Use the `DEFINE/KEY` and `DELETE/KEY` statements to create your own key definition file, as described in the following sections.

DEFINE/KEY Statement

The `DEFINE/KEY` statement assigns a new function to a particular key. Use the following syntax for the statement:

```
DEFINE/KEY [/STATE=EXTEND] key_name function
```

| | |
|------------------------------|--|
| <code>/STATE</code> | Optional. Default: nonextend mode. Redefines the key in extend mode. |
| <code><i>key_name</i></code> | Standard key name. |
| <code><i>function</i></code> | TN3270 function you want mapped to this key. |

You can define most of the named keys both in normal (nonextend) mode and in extend mode.

You can define the control keys (and the synonyms for them) in normal mode only. Do not specify the qualifier `/STATE=EXTEND`.

The following example assigns the `EXIT` function to the key sequence `EXT + Z`:

```
$ DEFINE/KEY/STATE=EXTEND "Z" EXIT
```

DELETE/KEY Statement

The `DELETE/KEY` statement removes the function assigned to a particular key. Use the following format:

```
DELETE/KEY [/STATE=EXTEND] key_name
```

| | |
|------------------------------|--|
| <code>/STATE</code> | Optional. Default: nonextend mode. Deletes the key in extend mode. |
| <code><i>key_name</i></code> | Standard key name. |

Example:

The following example removes the default value of `EXIT` from `Ctrl/Z`.

```
$ DELETE/KEY Ctrl/Z
```

Key Definition File: Example

By default, TN3270 maps 3270 functions to the numeric keypad.

The following example shows key definition statements in a key definition file. The definitions restore the numeric keypad on a VT220 keyboard.

```
DEFINE/KEY KP0 "0"
DEFINE/KEY KP1 "1"
DEFINE/KEY KP2 "2"
DEFINE/KEY KP3 "3"
DEFINE/KEY KP4 "4"
```



```
DEFINE/KEY      KP5 "5"  
DEFINE/KEY      KP6 "6"  
DEFINE/KEY      KP7 "7"  
DEFINE/KEY      KP8 "8"  
DEFINE/KEY      KP9 "9"  
DEFINE/KEY      period "."  
DEFINE/KEY      comma ","  
DEFINE/KEY      minus "-"  
DEFINE/KEY      Select extend  
DEFINE/KEY      Prev_screen reset
```

This example restores the key normally associated with the EXT function (KP.) as the keypad decimal point. When you assign a key another function, you remove its default value. Therefore, because some TN3270 functions rely on an EXT function, the EXT function is defined to correspond to the Select key. This example also restores the key normally associated with the RESET function (KP0) as the keypad 0 key. The example then defines the RESET function to correspond to the Prev Screen key

4.12.9.5.1. Interactive Definitions: DEF KEY Function

Use the DEF KEY function to define or redefine a key interactively. Your new definition exists until you log out from the remote host or disconnect from it.

When you invoke the DEF KEY function, TN3270 displays a prompt in the status line at the bottom of your screen.

Example:

The following example shows the use of DEF KEY to define a key. You invoke the DEF KEY function by entering the Ctrl/K sequence, after which you are prompted for the key you want to define and the function to assign to that key.

Ctrl/K

```
Press the key that you want to define:  
Enter the function name or quoted character:
```

You can also use DEF KEY to remove an assigned function. A null reply to the following prompt removes the definition currently in effect for that key:

```
Enter the function name or quoted character:
```

What you enter during the DEF KEY dialog is subject to translation from the National Character Set to the DMCS.

You cannot redefine a key that exists on your terminal if it lacks a DMCS equivalent.

4.12.9.6. TN3270 Problem Solving

During a TELNET session in which you have invoked TN3270, you might experience the following problems:

Problem

- The keyboard keys do not work properly.
- Messages, such as the status line messages, do not appear in reverse video.
- You receive a message indicating that your terminal is an unsupported model.

You cannot use TN3270 on a VT131 model terminal that is running in block mode.

Solution for a VT100-Series Terminal

Use Set-Up mode to verify that your terminal is in ANSI mode. Enter the following command:

```
$ SET TERMINAL /INQUIRE
```

Solution for a VT200-Series Terminal or a Terminal Connected to Either a Personal Computer or a Workstation

1. Use Set-Up mode to verify that your terminal is:

- In ANSI mode
- Set to VT100 or VT200 emulation mode

2. Check the Communications Menu:

The terminal communications line must be set for 8-bit characters. To check, enter the following command:

```
$ SET TERMINAL /INQUIRE
```

Solution for a Terminal with a National Language Keyboard

Ensure that your terminal is set up to correspond to your keyboard.

Problem

You receive a message indicating that the screen size (or the alternate screen size) specified by the remote host is too big.

Solution

Use Set-Up mode to change to a valid screen size (see Section 4.12.1).

Problem

You try to use the RECORD or PLAY function, but you get an error message indicating that you have a bad key-sequence file.

Solution

The file that stores the recorded key sequence is incompatible with the current version of the software or is corrupted.

Ask your system manager to do either of the following:

- Correct TCPIP\$RECSEQ.DAT in your SYSS\$LOGIN directory.
- Delete TCPIP\$RECSEQ.DAT.

If the system manager must delete this file, rerecord all the key sequences you had stored on the PF keys.

4.12.10. Debugging Application Programs Using the IBM 3270 Model Terminal Emulator

Visible attribute mode provides a way to debug application programs. After you use the DSP ATT (display attributes) function to enable visible attribute mode, all attribute characters are visible. Attribute characters are characters that appear at the start of a field to indicate the following information:

- How the field appears on the screen:
 - At normal intensity
 - At high intensity
 - Invisibly
- What type of data the application expects in the field:
 - Numeric
 - Alphabetic
 - Alphanumeric

The following information shows:

- How to enter and exit visible attribute mode (see Section 4.12.10.1)
- The screen displays (see Section 4.12.10.2)

4.12.10.1. Entering and Exiting Visible Attribute Mode

The displays described in this section rely on your terminal's ability to produce reverse video and bold characters.

Invoking the DSP ATT function toggles in and out of visible attribute mode.

- The first time you invoke this function, the following actions take place:
 - The screen is refreshed.
 - The attribute characters appear either in reverse video or underlined.
- The second time you invoke this function, the following actions take place:
 - This mode is turned off.
 - The screen is refreshed and returns to normal mode.

4.12.10.2. Visible Attribute Mode Displays

The attribute characters are displayed in reverse video, bold symbols. Attribute characters indicating numeric fields are also underlined. All other characters are displayed normally. Table 4.7 lists the attribute characters and their meanings.

Table 4.7. Displays in Visible Attribute Mode

| Character | Meaning |
|-----------|--|
| n | Unprotected field with normal intensity follows. |
| N | Protected field with normal intensity follows. |
| d | Following unprotected field is light-pen-detectable. |
| D | Following protected field is light-pen-detectable. |
| h | Following unprotected field has high intensity. |
| H | Following protected field has high intensity. |
| i | Unprotected nondisplay field follows. |
| I | Protected nondisplay field follows. |

4.13. Command Descriptions

To start TELNET, enter either the TELNET command or the TN3270 command at the DCL prompt.

To use TELNET commands, enter them at the TELNET> prompt.

This section provides complete descriptions of each TELNET command. The related ENABLE and DISABLE commands are presented together (see the description for ENABLE).

CONNECT

CONNECT — Establishes a TELNET connection between your local system and a remote host. You can run one session or 10 or more simultaneous sessions (only one session if you invoke TN3270).

DCL Syntax

CONNECT *host* [*port** [*terminal_type*]]

* Required if you specify terminal type.

UNIX Syntax

open *host* [*port*] [*terminal_type*]

Parameters

host

Required.

Remote host to which you want to connect.

port

Optional without *terminal_type*. Required with *terminal_type*. Default: 23.

TELNET port on the remote host. Specify this parameter if:

- You are invoking TN3270.
- You are connecting to a host that does not use the standard TELNET port.

terminal_type

Optional. Default: model of your physical terminal.

Terminal model that you want your physical terminal to function as. Specify one of the following:

- For a session running TN3270, the terminal model to emulate. Enter one of the following:
 - IBM-3278-2
 - IBM-3278-3
 - IBM-3278-4
 - IBM-3278-5
- For a non-TN3270 session, any terminal type recognized by the remote host, such as VT100, VT200, VT300, VT400, and VT500.

Examples

1. TELNET> **CONNECT MYBUD**

Establishes a TELNET connection to remote host MYBUD.

2. TELNET> **CONNECT DEBTS 23 IBM-3278-2**

Establishes a TELNET connection to remote host DEBTS and runs TN3270. Your terminal functions as an IBM-3278-2 model terminal. For syntax reasons, specifying a port number is required.

3. TELNET> **CONNECT 130.180.5.5**

Establishes a TELNET connection to the host at IP address 130.180.5.5.

4. TELNET> **CONNECT REVIN 31**

Establishes a TELNET connection to remote host `revin`. The connection is at port 31 on `revin`.

5. % **Ctrl/]**
TELNET> **CONNECT QUIK**
.
.
.
%

During a TELNET session with a UNIX host, pressing Ctrl/] escapes to the TELNET prompt. Another CONNECT command establishes a second session, this one to UNIX host `quik`.

BIND_SESSION

BIND_SESSION — Creates a TELNET terminal device (TNA *x*;) and connects to a network device (BG *x*:). If successful, returns the TNA device name (TNA *x*;) in the DCL symbol

\$TELNET_DEVICE. Network input and output operations can then be performed through the created TELNET device using terminal driver \$QIO operations.

DCL Syntax

BIND_SESSION *network_device* [/PROTOCOL=*option*]

Parameters

network_device

Required.

An existing network device.

Qualifiers

/PROTOCOL=*option*

Optional. Default: NONE.

Options include:

- NONE

Data is sent with no interpretation (raw).

- NVT

Network Virtual Terminal (NVT), TELNET's internal representation of a standard network terminal. NVT format is standard 7-bit ASCII code transmitted in 8-bit octets, the canonical form of data representation used by both the client and server.

- TELNET

Standard TELNET protocol.

- RLOGIN

Standard RLOGIN protocol.

Example

```
TELNET> BIND_SESSION BG393: /PROTOCOL=NVT
```

CREATE_SESSION

CREATE_SESSION — Establishes an outbound TELNET pseudo device (network terminal) and connects it to a remote listener (port). This is also known as a **reverse TELNET** connection.

DCL Syntax

```
CREATE_SESSION host port [ unit ]  
                [ /[ NO ]TIMEOUT=option ]  
                [ /PERMANENT ]
```

[/PROTOCOL= *option*]

Parameters

host

Required.

Remote host to which you want to connect.

port

Required.

TELNET port on the remote host.

unit

Optional. Default: 0

The decimal number specifying the unit number for the pseudo device (TNA *x*). The default 0 specifies that TCP/IP Services should pick the next available unit number. If the requested unit number is already in use, the next available unit number is used. In all cases, the software notifies you of the unit number chosen.

Qualifiers

/TIMEOUT

/NOTIMEOUT

Optional. Default: /NOTIMEOUT

- /TIMEOUT

Creates a TNA device that has the following connection attributes:

- NOIDLE – The connection is broken when the device is finally deassigned. The device will automatically reconnect when data is written to it.
- IDLE – Specifies the idle time for the device. If the device is idle for at least the specified amount of time (note that the time has a granularity of one second), then the connection will be broken. Idle means that the device has neither received nor sent any data for the idle period.
- NORECONNECTION – The device does not automatically retry reconnections if they fail.
- RECONNECTION – When data is written to the device and the device is not connected, this value determines the interval between reconnection attempts. For example, if an application writes to a TNA with a RECONNECTION-0:1:00, and if the first connection attempt fails, then subsequent connection attempts will be made in 1-minute intervals.
- /NOTIMEOUT

Creates a TNA device that breaks the connection when the device is finally deassigned (the last channel assignment is deassigned).

/PERMANENT

Optional.

Creates a TNA device that disconnects on deassignment and reconnects on assignment.

/PROTOCOL=*options*

Optional. Default: NONE. Options include:

- NONE

Data is sent with no interpretation (raw).

- NVT

Network Virtual Terminal (NVT), TELNET's internal representation of a standard network terminal. NVT format is standard 7-bit ASCII code transmitted in 8-bit octets, the canonical form of data representation used by both the client and server.

- TELNET

Standard TELNET protocol.

- RLOGIN

Standard RLOGIN protocol.

Examples

1. TELNET> **CREATE_SESSION DEBTS 23 2**

Establishes a network terminal known as TNA2, and connects this device to port 23 on remote host DEBTS.

2. TELNET> **CREATE_SESSION /TIMEOUT=(NOIDLE, RECONNECTION=nn)**

Creates a device that disconnects on deassignment and reconnects when data is written to it.

3. TELNET> **CREATE_SESSION /NOTIMEOUT**

Creates a device that is not reusable; the device disconnects on deassignment and is deleted.

4. TELNET> **CREATE_SESSION /TIMEOUT=(IDLE=0:0:30, RECONNECTION=0:2:00)**

Creates a device that times out after being idle for 30 seconds and that retries connection attempts at 2-minute intervals.

DELETE_SESSION

DELETE_SESSION — Deletes an outbound TELNET pseudo device (network terminal) created by the **CREATE_SESSION** command. If the device was not created with the **CREATE_SESSION** command, the command returns an error.

DCL Syntax

DELETE_SESSION *unit*

Parameters

unit

Required.

The decimal number specifying the unit number of the pseudo device (TN *x*) to be deleted.

Example

```
TELNET> DELETE_SESSION 2
```

Deletes the network terminal known as TNA2.

DISCONNECT

DISCONNECT — Terminates the current remote connection. If you terminate a session with a remote OpenVMS host, the connection is closed by your local host. However, the process on the remote host is still running. To terminate it, enter a LOGOUT command.

DCL Syntax

DISCONNECT

UNIX Syntax

close

ENABLE (DISABLE) AUTOFLUSH

ENABLE (DISABLE) AUTOFLUSH — Enables or disables the automatic flushing of output when you send the interrupt character. **Enabled** — The data in the data buffer remains visible until the buffer is empty. **Disabled** — The data buffer is emptied and the display is terminated. This provides fast system response to the interrupt character. Default: ENABLE AUTOFLUSH.

DCL Syntax

ENABLE AUTOFLUSH

DISABLE AUTOFLUSH

UNIX Syntax

toggle autoflush

ENABLE (DISABLE) AUTOSYNCH

ENABLE (DISABLE) AUTOSYNCH — Enables or disables the sending of the synchronization and interrupt characters in urgent mode. **Enabled** — The local host sends an interrupt character in urgent mode, and the remote host immediately processes it. **Disabled** — TELNET sends the interrupt character in sequence with the other characters in the stream, and the remote host processes this character in the sequence received. Default: DISABLE AUTOSYNCH.

DCL Syntax

ENABLE AUTOSYNCH

DISABLE AUTOSYNCH

UNIX Syntax

toggle autosynch

ENABLE (DISABLE) BINARY

ENABLE (DISABLE) BINARY — Enables or disables the transmission of data in binary mode.

Enabled — The EOL (end-of-line) character is not mapped to Return LF (the carriage return/line feed combination). Use ENABLE BINARY when the remote host expects each line to end with a carriage return/line feed combination. Binary mode provides interaction when the remote host expects special characters or does not support automatic negotiation of the TELNET binary option. **Disabled** — EOL is sent as Return LF (the carriage return/line feed combination). Default: DISABLE BINARY

DCL Syntax

ENABLE BINARY

DISABLE BINARY

UNIX Syntax

toggle binary

ENABLE (DISABLE) CRLF

ENABLE (DISABLE) CRLF — Enables or disables the sending of carriage returns as Return LF (the carriage return/line feed combination) at the end of each line. Use ENABLE CRLF if the remote host expects Return LF at the end of each line. Use DISABLE CRLF if the remote host interprets Return as Return LF, which is CR mode. Default: ENABLE CRLF.

DCL Syntax

ENABLE CRLF

DISABLE CRLF

UNIX Syntax

toggle crlf

ENABLE (DISABLE) CRMOD

ENABLE (DISABLE) CRMOD — Enables or disables the mapping of received carriage returns.

With this mapping, the remote host sends each line with Return LF (the carriage return/line feed combination) at the end of each line. Use ENABLE CRMOD if your terminal expects each line to end

with Return LF. Use DISABLE CRMOD if your terminal expects Return null at the end of each line. Default: DISABLE CRMOD.

DCL Syntax

ENABLE CRMOD

DISABLE CRMOD

UNIX Syntax

toggle crmod

ENABLE (DISABLE) DEBUG

ENABLE (DISABLE) DEBUG — Enables or disables the display of data in hexadecimal. **Enabled** — Data is displayed in both hexadecimal and readable text. **Disabled** — Data is displayed in readable text. Default: DISABLE DEBUG.

DCL Syntax

ENABLE DEBUG

DISABLE DEBUG

UNIX Syntax

toggle netdata

EXAMPLE

```
% Ctrl/Z (characters not echoed)
TELNET> enable debug Return
TELNET> display Return
.
.
.
Will print network data flow in hexadecimal
.
.
.
TELNET>)resume Return
SEND [ 0] D A
RCVD [ 0] D A
RCVD [ 0] 746E7069782E6C6B672E6465632E636F6D3E20
%
ls Return
SEND [ 0] 6C
RCVD [ 0] 6C l
SEND [ 0] 73
RCVD [ 0] 73 s
SEND [ 0] D A
RCVD [ 0] D A
RCVD [ 0] 62696E20202020202020...
RCVD [ 32] 7074 D A
```

```
french.estud.oiseau      russian.estud.ptitsa    fences
typescript              verio
%
```

Escapes from a session with a UNIX host, enables debug mode, resumes the session, and asks for a list of files in the working directory. Both hexadecimal data and readable data are displayed.

ENABLE (DISABLE) LOCAL_CHARS

ENABLE (DISABLE) LOCAL_CHARS — Enables or disables the translation of the certain terminal control characters in to TELNET protocol sequences.

Additional Information

The following terminal control characters can be translated:

- Interrupt
- Flush Output
- Are You There
- Kill
- Erase
- Quit

With local characters:

- **Enabled** — The local host sends the control characters (in the preceding text) translated into TELNET sequences. For example, Ctrl/T becomes IAC AYT.

Enabled mode is appropriate when the remote and local hosts implement different control characters. The remote host does not recognize certain control characters. Therefore, the local host interprets these control characters before sending them to the remote host.

- **Disabled** — The local host sends these control characters uninterpreted. They are interpreted by the remote host.

Before you communicate in disabled mode, ensure that the remote and local hosts use the same control characters.

Default: DISABLE LOCAL_CHARS

DCL Syntax

ENABLE LOCAL_CHARS

DISABLE LOCAL_CHARS

UNIX Syntax

toggle localchars

ENABLE (DISABLE) OPTIONS_VIEW

ENABLE (DISABLE) OPTIONS_VIEW — Enables or disables the display of option negotiations between the local system and the remote host during the session. **Enabled** — TELNET displays the option negotiations between your local system and the remote host. **Disabled** — TELNET does not display the option negotiations. This mode is suitable for most communications. Default: DISABLE OPTIONS_VIEW.

DCL Syntax

ENABLE OPTIONS_VIEW

DISABLE OPTIONS_VIEW

UNIX Syntax

toggle options

EXIT

EXIT — Closes any open sessions, exits from TELNET, and returns to the DCL prompt. If you terminate a session with a remote OpenVMS host, the connection is closed by your local host. However, the process on the remote host is still running. To terminate it, enter the LOGOUT command.

DCL Syntax

EXIT

UNIX Syntax

quit

HELP

HELP — Displays online help for TELNET or TN3270 commands.

Syntax

HELP [*telnet_command*]

Parameter

telnet_command

Optional.

Specific DCL TELNET command about which you want information.

Examples

1. TELNET> **HELP CONNECT**

Provides information about the CONNECT command.

2. TELNET> **HELP OPEN**

Displays the message *Sorry, no documentation on OPEN.*

To get help for a command, enter the DCL command name.

RESUME

RESUME — Resumes an open TELNET or TN3270 session that you interrupted with the escape sequence.

Additional Information

When you run simultaneous multiple sessions (TELNET only):

- To resume a particular session, specify a session number.
- To resume the active session, omit the session number.
- If no session is active, you must specify a session number.

Note

TELNET interprets the active session as the last session with which you communicated. If that communication ended with you logging out, you have no active sessions. However, you might have other waiting (alive) sessions.

DCL Syntax

RESUME [*session_number*] Return

UNIX Syntax

Return

Parameters

session_number

Optional. Default: the active session.

Use *session_number* when you run multiple TELNET sessions. It resumes the session with the specified number.

Examples

1. \$ **Ctrl/]** (**characters not echoed**)
TELNET> **SHOW STATUS** Return
Session 1 Active Host FINDER
.

```
.  
.  
TELNET> RESUME Return  
$
```

This example:

- Starts at the prompt of remote OpenVMS host FINDER.
- Escapes from FINDER and returns to the local TELNET prompt.
- Issues SHOW STATUS, which displays one active session.
- Returns to FINDER's prompt.

2. % **Ctrl/]** (characters not echoed)

```
TELNET> SHOW STATUS Return  
Session 2 Active Host LUNA  
.  
.  
.  
Session 1 Waiting Host SOLAR  
TELNET> RESUME 1 Return  
%
```

This example:

- Starts at the prompt of UNIX host luna.
- Escapes from luna.
- At the TELNET prompt, issues SHOW STATUS, which displays two active sessions, the active one with luna and another with host solar, whose status is "waiting."

The RESUME 1 command returns to "waiting" host solar.

SEND AO

SEND AO — SEND AO (Abort Output) aborts the output of the last remote command you entered, while the command continues to execute. If you issue another SEND AO, the output resumes if the command is still executing. Use this command when the remote host does not recognize Ctrl/O as the flush output character or if you want to terminate the output but not the execution of the process.

DCL Syntax

SEND AO

UNIX Syntax

send ao

Example

```
% cd /bin  
% ls -l
```

```
total 3464
-rwxr-xr-x  2 root 32768 Oct 19  1996 STTY
-rwxr-xr-x  2 root  5120 Oct 19  1996 Ctrl/] (characters not echoed)

TELNET> SEND AO
^O
%
```

During a directory listing, the TELNET escape sequence (not echoed to the screen) returns to TELNET prompt. The SEND AO command aborts the UNIX `ls` command.

SEND AYT

SEND AYT — SEND AYT (Are You There) reports if you are still connected to an established connection.

DCL Syntax

SEND AYT

UNIX Syntax

`send ayt`

Examples

```
1. $ Ctrl/]
TELNET> send ayt
%TELNET-I-SESSION, Session 01, host d45lt, port 23
$
$_TNA375: 13:53:18 (DCL) CPU=00:00:00.28 PF=448 IO=104 MEM=53
$
```

OpenVMS client to OpenVMS server.

```
2. % Ctrl/]
TELNET> send ayt
%TELNET-I-SESSION, Session 01, host LUNA, port 23
%
[YES]
Return
%
```

OpenVMS client to UNIX server.

```
3. $ Ctrl/]
telnet> send ayt
$_TNA37: 13:50:20 (DCL) CPU=00:00:00.12 PF=331 IO=98 MEM=66
$
```

UNIX client to OpenVMS server.

```
4. % Ctrl/]
telnet> send ayt

[Yes]
```



```
Return  
%
```

UNIX client to UNIX server.

SEND BRK

SEND BRK — SEND BRK (Break) terminates execution of the last command you entered at the remote host. Use this command when the remote host does not recognize Ctrl/C as an interrupt character.

DCL Syntax

SEND BRK

UNIX Syntax

send brk

Example

```
% cd /bin  
% ls -l  
total 1464  
-rwxr-xr-x  2 root 32768 Oct 19  1988 STTY  
-rwxr-xr-x  2 root  5120 Oct 19  1988 [  
-rwxr-xr-x  1 root 45056 Oct 19  1988 adb  
lrwxr-xr-x  1 root   13  Aug 21 17:41 ar -> ../usr/bin/ar  
lrwxr-xr-x  1 root   13  Aug 21 17:41 as -> ../usr/bin/as  
Ctrl/] (characters not echoed)
```

```
TELNET> SEND BRK
```

This example does the following:

- Enters the UNIX `ls` command.
- Enters the TELNET escape sequence.
- Enters the TELNET SEND BRK command, which terminates execution of `ls` at the remote host.

SEND EC

SEND EC — SEND EC (Erase Character) deletes the last character you typed at the remote host. Use this command when the remote host does not recognize your Delete key.

DCL Syntax

SEND EC

UNIX Syntax

send ec

Examples

```
% mail Ctrl/] (characters not echoed)
TELNET> SEND EC Return
Mail $Revision 4.2.4.2 $ Type ? for help.
"/usr/spool/mail/debts": 1 message 1 new
>N 1 debts Tue Sep 15 13:39 8/161 "Team Building"
&
```

This example:

- Misspells the UNIX mail command.
- Enters the TELNET escape sequence (not echoed to the screen) to return to the TELNET prompt.
- Enters the TELNET SEND EC command, which deletes the last character typed (l) and returns to the remote host.

SEND EL

SEND EL — SEND EL (Erase Line) deletes the last line of text you entered on the remote host. Use this command when the remote host does not recognize your Delete key or command-line recall.

DCL Syntax

SEND EL

UNIX Syntax

send el

Example

```
% mail Ctrl/] (characters not echoed)
TELNET> SEND EL Return
% Mail
Mail version 2.18 5/19/83. Type ? for help.
"/usr/spool/mail/finder": 1 message 1 new
>N 1 finder Tue Sep 15 13:39 8/161 "Getting Together"
&
```

This example:

- Misspells the UNIX Mail command.
- Enters the TELNET SEND EL command, which deletes the incorrect line mail and returns you to the remote host.
- Enters the Mail command.

SEND GA

SEND GA — SEND GA (Go Ahead) signals the remote host that your local system is ready. Some applications require GA commands in either one or both directions. (Usually, Go Ahead is suppressed, so sending a GA has no effect.)

DCL Syntax

SEND GA

UNIX Syntax

send ga

SEND IP

SEND IP — SEND IP (Interrupt Program) interrupts the execution of the last command you entered on the remote host. The interrupt character clears the input and output paths to the remote host. The remote host interrupts the program that is processing. (This command has no effect in binary mode.) Use this command if either your terminal or the remote host does not recognize the default interrupt character, Ctrl/C.

DCL Syntax

SEND IP

UNIX Syntax

send ip

SEND NOP

SEND NOP — SEND NOP (No Operation) tells you whether your local host can send data to the remote host and the remote host can receive the data. If you get an %TELNET-E-INETEROR error message, there is a problem with the connection; the remote host is not able to receive data. If you get an %TELNET-S-REMCLOSED status message, the connection with the remote host has been closed. If you do not get an error message, the connection is active.

DCL Syntax

SEND NOP

UNIX Syntax

send nop

Examples

1. % Ctrl/] (characters not echoed)
TELNET> SEND NOP Return
%TELNET-I-SESSION, Session 01, host nyx, port 23

No error message indicates the connection is active. (The information message also indicates the connection is active.)

2. % Ctrl/] (characters not echoed)
TELNET> SEND NOP
%TELNET-S-REMCLOSED, Remote connection closed

```
-TELNET-I-SESSION, Session 01, host nyx, port 23  
TELNET>
```

Indicates your connection has been broken.

SEND SYNCH

SEND SYNCH — The SEND SYNCH command clears the communications path between your local system and the remote host.

Additional Information

The SYNCH is sent in urgent mode (out-of-band, OOB). As a result, the following actions occur:

1. The local host immediately sends an interrupt character, placing it at the front of the data stream sent to the remote host.
2. The remote host immediately processes the interrupt character, ignoring any incoming data not yet processed, and then including a TELNET synchronization or interrupt character in the data stream it sends back to the local host.
3. The local host throws away all incoming data (rather than processing that data) until it detects the synchronization or interrupt character. This provides faster response time to the synchronization and interrupt characters.

DCL Syntax

SEND SYNCH

UNIX Syntax

send synch

SET ECHO

SET ECHO — Sets the echo character.

Additional Information

Use this command if either your terminal or the remote system does not recognize the default echo character. Enter the following sequence of characters:

1. Opening quotation marks
2. A circumflex (^)
3. The new echo character
4. Closing quotation marks

DCL Syntax

SET ECHO "^ *character*"

UNIX Syntax

`set echo "^ character"`

Parameters

`"^ character"`

Required.

Character you want to use as the echo character.

EXAMPLE

```
TELNET> SET ECHO "^m"  
Echo character is '^M'.
```

Sets the echo control character to either m or M.

SET ERASE

SET ERASE — Sets the erase character.

Additional Information

The erase character deletes, either locally or remotely, the last character in the type-ahead buffer. (This character has no effect in binary mode.)

Use this command if either your terminal or the remote system does not recognize the default erase character, the Delete key.

Enter the following sequence of characters:

1. Opening quotation marks
2. A circumflex (^)
3. The new erase character
4. Closing quotation marks

DCL Syntax

`SET ERASE "^character"`

UNIX Syntax

`set erase "^character"`

Parameters

`"^character"`

Required.

Character you want to use as the erase character.

Example

```
TELNET> SET ERASE "^P"  
Erase character is '^p'.
```

Sets the erase control character to either p or P.

SET ESCAPE

SET ESCAPE — Sets the escape character.

Additional Information

The escape character returns you to the TELNET prompt. When you run multiple sessions, you can set different escape sequences for each connection.

Use this command if either your terminal or the remote system does not recognize the default escape character, Ctrl/]. Enter the following sequence of characters:

1. Opening quotation marks
2. A circumflex (^)
3. The new escape character
4. Closing quotation marks

DCL Syntax

```
SET ESCAPE "^ character"
```

UNIX Syntax

```
set escape "^ character"
```

Parameters

```
"^ character"
```

Required.

Character you want to use as the escape character.

Example

```
TELNET> SET ESCAPE "^P"  
Escape character is '^p'.
```

Sets the escape control character to either p or P.

SET FLUSHOUTPUT

SET FLUSHOUTPUT — Sets the flush output character.

Additional Information

Use this command if either your terminal or the remote host does not recognize the default flush output character, Ctrl/O.

Enter the following sequence of characters:

1. Opening quotation marks
2. A circumflex (^)
3. The new flush output character
4. Closing quotation marks

DCL Syntax

SET FLUSHOUTPUT "*^character*"

UNIX Syntax

set flushoutput "*^character*"

Parameter

"^character"

Required.

Character you want to use as the flush output character.

Example

```
TELNET> SET FLUSHOUTPUT "^P"  
Flush output character is '^p'.
```

Sets the flush output control character to either p or P.

SET INTERRUPT

SET INTERRUPT — Sets the interrupt character.

Additional Information

The interrupt character clears the input and output paths to the remote host. The remote host interrupts the program that is processing. (This character has no effect in binary mode.)

Use this command if either your terminal or the remote host does not recognize the default interrupt character, Ctrl/C.

Enter the following sequence of characters:

1. Opening quotation marks
2. A circumflex (^)
3. The new interrupt character
4. Closing quotation marks

DCL Syntax

```
SET INTERRUPT "^character"
```

UNIX Syntax

```
set interrupt "^character"
```

Parameter

"^character"

Required.

Character you want to use as the interrupt character.

EXAMPLE

```
TELNET> SET INTERRUPT "^a"  
Interrupt character is '^A'.
```

Sets the interrupt control character to either a or A.

SET KILL

SET KILL — Sets the kill character.

Additional Information

The kill character discards, both locally and remotely, the entire type-ahead buffer. (This character has no effect in binary mode.)

Use this command if either your terminal or the remote host does not recognize the default kill character, Ctrl/U.

Enter the following sequence of characters:

1. Opening quotation marks
2. A circumflex (^)
3. The new kill character
4. Closing quotation marks

DCL Syntax

SET KILL "*^character*"

UNIX Syntax

set kill "*^character*"

Parameter

^character

Required.

Character you want to use as the kill character.

Example

```
TELNET> SET KILL "^q"  
Kill character is '^Q'.
```

Sets the kill control character to either q or Q.

SET MODE

SET MODE — Sets the mode of transmission.

Additional Information

The mode of transmission can be either character mode or line mode. Character mode is the default. Use character mode when you run a character-processing text editor on the remote host. With character mode, your local system sends data a character at a time to the remote host with which you have a connected session, and the remote host echoes the characters back for display on your local system. (Sometimes several characters may be sent in a burst for performance optimization, in which case the remote server usually replies with bursts of characters, but not a line at a time.)

To use line mode, the remote host server must support line mode. The local host echoes characters. Line mode allows the following:

- Signal trapping (such as for application programs on remote UNIX hosts that sense traps or special events)
- Local character editing
- Tab expansion (where a tab is more than simply the TAB character)

This command overrides the ENABLE LOCAL_CHARS command.

Before you enter this command, establish a remote connection.

DCL Syntax

SET MODE {CHAR | LINE}

UNIX Syntax

mode *mode*

Parameter

CHAR

LINE

Required.

Transmission mode you want to set. Specify either of the following:

- CHAR – Data is transmitted one character at a time.
- LINE – Data is transmitted one line at a time.

SET QUIT

SET QUIT — Sets the quit character, an alternate interrupt character.

DCL Syntax

SET QUIT "**^** *character*"

UNIX Syntax

set quit "**^** *character*"

Parameter

^*character*

Required.

Character you want to use as the quit character.

Example

```
TELNET> SET QUIT "^i"  
Quit character is '^I'.
```

Sets the alternate interrupt control character to either i or I.

SET TERMINAL

SET TERMINAL — Sets the default terminal type for future TELNET or TN3270 connections.

Syntax

SET TERMINAL /DEVICE= *type*

Qualifiers

/DEVICE= type

Required.

Terminal model. Specify one of the following:

- A terminal model.
- An IBM terminal to emulate. Enter the full specification for one of the following:
 - IBM-3278-2
 - IBM-3278-3
 - IBM-3278-4
 - IBM-3278-5

Example

```
TELNET> SET TERMINAL/DEVICE=IBM-3278-2
Terminal type is set to IBM-3278-2
TELNET>
```

Runs TN3270. The terminal is emulating an IBM 3278-2 model terminal.

SHOW DEVICE

SHOW DEVICE — Displays status information about TELNET devices.

DCL Syntax

```
SHOW DEVICE [ device_name ] [ /FULL ]
```

Parameter

device_name

Optional. TNA device name. For example, TNA245:.

Qualifier

/FULL

Optional.

Shows detailed information about TNA devices on the local system.

Examples

1. TELNET> **SHOW DEVICE TNA281:**
TNA281: BG9526: Temporary Local: condor:23

Remote: freebid:1033

Displays status of a particular TNA device.

2. TELNET> **SHOW DEVICE**

| ① | ② | ③ | ④ | | |
|--------|---------|-----------|---------|---------------------------|--|
| TNA10: | BG495: | Temporary | Local: | condor:23 | |
| | | | Remote: | freebid:1059 | |
| TNA12: | BG658: | Temporary | Local: | condor:23 | |
| | | | Remote: | pigdog:1455 | |
| TNA13: | BG671: | Temporary | Local: | condor:23 | |
| | | | Remote: | pigdog:1456 | |
| TNA35: | BG2993: | Temporary | Local: | condor:23 | |
| | | | Remote: | projector:1044 | |
| TNA37: | BG2999: | Temporary | Local: | condor:23 | |
| | | | Remote: | pigdog:1459 | |
| TNA38: | BG3000: | Temporary | Local: | condor:23 | |
| | | | Remote: | pigdog:1470 | |
| TNA47: | BG3393: | Temporary | Local: | condor:23 | |
| | | | Remote: | 1-22-222-37.*.com:1069 | |
| TNA58: | BG3866: | Temporary | Local: | condor:23 | |
| | | | Remote: | pcruth.mel.dec.com:1043 | |
| TNA59: | BG3878: | Temporary | Local: | condor:23 | |
| | | | Remote: | lexser13.lex.dec.com:1090 | |
| TNA60: | BG3910: | Temporary | Local: | condor:23 | |
| | | | Remote: | 1-20-244-54.*.com:1635 | |
| TNA61: | BG3932: | Temporary | Local: | condor:23 | |
| | | | Remote: | lexser3.lex.dec.com:1093 | |
| TNA62: | BG3933: | Temporary | Local: | condor:23 | |
| | | | Remote: | tcpipa:1801 | |
| TNA63: | | Temporary | | | |

Displays status of all TNA devices on the local system. Command output includes:

- ① The TNA device (terminal device)
- ② The associated BG device (network device)
- ③ Whether the TNA device is permanent or temporary
- ④ Local and remote host names and port numbers

3. TELNET> **SHOW DEVICE/FULL**

```
Device TNA7:
  Access port name:      "Host: 16.99.999.140      Port: 1310"
  Characteristics:      (none)
  Connection attempts:  0 (tries)
  Connection interval:  0 (seconds)
  Connection timeout:   0 (seconds)
  Data high limit:      512 (bytes at VCI port)
  Data low limit:       256 (bytes at VCI port)
  Idle interval:        0 (seconds)
  Idle timeout:         0 (seconds)
  Network device name:  BG266:
  Protocol:             TELNET
  Local address:        16.99.999.100 (condor)
                        port:          23
  Remote address:       16.99.999.140 (pigdog.dec.com)
                        port:          1310
  Service type:         None
```

Displays detailed information about all TNA devices that exist on the local system. The information shown in the example is output for each TNA device.

SHOW PARAMETERS

SHOW PARAMETERS — Displays current TELNET or TN3270 parameter settings. If you run multiple sessions, the display applies to the active session.

DCL Syntax

SHOW PARAMETERS

UNIX Syntax

display

Example

```
TELNET> SHOW PARAMETERS
Will flush output when sending interrupt characters
Won't send interrupt characters in urgent mode
Will map carriage return on output
Won't recognize certain control characters
Won't show option negotiation
Won't print network data flow in hexadecimal
[^^]      echo
[^]]      escape
[^?]      erase
[^O]      flushoutput
[^C]      interrupt
[^U]      kill
[^Y]      quit
[^T]      areyouthere
TELNET>
```

Displays the parameter settings for the active session, revealing the following information:

- Automatic flushing (AUTOFLUSH) of output is enabled.
- Sending of interrupt characters in urgent mode (AUTOSYNCH) is disabled.
- Mapping of received carriage returns (CRMOD) is enabled.
- Mapping of carriage returns as Return LP on output (CRLF) is disabled.
- Interpretation of control characters (LOCAL_CHARS) is enabled. The remote host does not recognize certain control characters; therefore, the local host interprets them.
- Display of option negotiations (OPTIONS_VIEW) between the local and remote hosts is disabled.
- The display or printing of data in hexadecimal (DEBUG) is disabled. Therefore, TELNET displays the data in readable text only.

- The control characters are interpreted as listed.

SHOW SESSION

SHOW SESSION — Displays the session information about your current TELNET sessions (or TN3270 session) and, if you are running multiple TELNET sessions, about the waiting sessions.

DCL Syntax

SHOW SESSION

UNIX Syntax

status

Examples

```
1. TELNET> SHOW SESSION
%TELNET-E-NOSESSION, No active session

TELNET> CONNECT LUNA
%TELNET-I-Trying, Trying... 192.1.2.3
%TELNET-I-SESSION, Session 01, host luna, port 23
-TELNET-I-Escape, Escape character: '^]'

LUNA - Unauthorized access is prohibited
Username: BURNS
Password: (password not echoed)

Welcome to OpenVMS Alpha Version 7.3 on node LUNA
$ Ctrl/] (characters not echoed)

TELNET> SHOW SESSION
Session 01, host LUNA, port 23 (default active port)

TELNET>
```

Displays information about current sessions. The information returned for the first SHOW SESSION command reveals that the local host has no active sessions. The user then connects to host LUNA and returns to the TELNET prompt to display session information once again. This time, the SHOW SESSION command displays information about the connection with LUNA.

```
2. TELNET> CONNECT ESTRELLA 23 IBM-3278-2
.
.
.
% Ctrl/] (characters not echoed)
TELNET> SHOW SESSION
Session 01, host LUNA, port 23
Session 02, host ESTRELLA, port 23 (default active session)
TELNET>
```

Here, the same user has established another connection, this time to host ESTRELLA. The SHOW SESSION command displays information about all sessions, revealing that the current active session is with host ESTRELLA.

SHOW STATUS

SHOW STATUS — Displays the status of the current TELNET or TN3270 session and, if you are running multiple sessions, about the waiting sessions. Status information can include information about open sessions, such as which one is active and which ones are waiting, the escape character and options currently set, and the number of data overruns and suspended network I/Os (inputs/outputs) detected.

DCL Syntax

SHOW STATUS

UNIX Syntax

status

Examples

1. TELNET> **SHOW STATUS**

No open sessions

Escape character: '^']'

TELNET> **CONNECT LUNA**

%TELNET-I-Trying, Trying ... 192.1.2.3

%TELNET-I-SESSION, Session 01, host LUNA, port 23

-TELNET-I-Escape, Escape character: '^']'

LUNA - Unauthorized access is prohibited

Username: **BURNS**

Password: **(password not echoed)**

Welcome to OpenVMS Alpha Version 7.3 on node LUNA

\$ **Ctrl/]**

TELNET> **SHOW STATUS**

Session 1 Active Host LUNA Port 23

Operating Mode: Character-at-a-time

Escape character: '^']'

Options:

Echo - Remote

Terminal Type - Local

Terminal Type - VT300

Suppress Go Ahead - Local

Suppress Go Ahead - Remote

Terminal Dataoverruns: 0

Suspended Network I/Os: 0

TELNET>

Session 1 Active Host LUNA

Operating Mode: Character-at-a-time

Escape character: '^']'

Options:

Echo - Remote

Terminal Type - Local

Terminal Type - DEC-VT300

Suppress Go Ahead - Local

```
    Suppress Go Ahead - Remote
Terminal Dataoveruns:      0
Suspended Network I/Os:   0
```

```
TELNET>
```

The user enters a `SHOW STATUS` command, which reveals that no active sessions have been established. After the user connects to host LUNA, the next `SHOW STATUS` command displays information about the active session with LUNA.

```
2. TELNET> CONNECT ESTRELLA 23 IBM-3278-2
.
.
.
% Ctrl/]          (characters not echoed)
TELNET> SHOW STATUS
Session 2 Active Host ESTRELLA Port 23
  Operating Mode: Character-at-a-time
  Escape character: '^]'
  Options:
    Echo - Remote
    Terminal Type - Local
    Terminal Type - VT300
    Suppress Go Ahead - Local
    Suppress Go Ahead - Remote
  Terminal Dataoveruns:      0
  Suspended Network I/Os:   0
Session 1 Waiting Host LUNA Port 23
TELNET>
```

Here, the user has established an additional session, this time with host ESTRELLA. The `SHOW STATUS` command displays information about the currently active session with ESTRELLA and the waiting session.

SPAWN

SPAWN — Suspends your current TELNET or TN3270 session and returns you to the local DCL prompt. To resume your session, log out at the DCL prompt.

DCL Syntax

SPAWN

UNIX Syntax

z

EXAMPLE

```
% date
Fri Sep 11 14:16:39 EDT 2002
% Ctrl/] (characters not echoed)

TELNET> SPAWN

$ SHOW TIME          11-Sep-2002 14:16:41
```



```
.  
. .  
$ LOGOUT  
Process GROUP_1 logged out at 11-Sep-2002 14:27:18.63  
  
TELNET> RESUME
```

The user returns to the TELNET prompt from the active session with a remote UNIX host. The user then enters the SPAWN command and, at the DCL prompt, displays the time and several other commands (not shown) before logging out and returning to the TELNET prompt to resume the active session.

TELNET

TELNET — Starts a TELNET session and does one of the following: displays the TELNET prompt, establishes a connection to a remote host, or establishes a connection to a remote host and runs TN3270.

DCL Syntax

```
TELNET [ host ] qualifier(s) [ port ] [unit ]  
      [ /AUTHENTICATE ]  
      [ /BIND_SESSION network_device  
      [ /CREATE_SESSION [ /[NO]TIMEOUT=option [/PERMANENT] /  
      PROTOCOL=protocol]]  
      [ /FORWARD
```

UNIX Syntax

telnet [*host*]

Parameters

host

Required with the /CREATE_SESSION qualifier; optional in all other cases. Default: None.

Remote host to which you want to connect. Specify one of the following:

- Host name
- IP address

port

Required with the /CREATE_SESSION qualifier; ignored in all other cases. Default: None.

Specifies the remote port to which you want to connect the pseudo device.

unit

Required with the /DELETE_SESSION qualifier; optional with the /CREATE_SESSION qualifier; ignored in all other cases. Default: 0.

With the /CREATE_SESSION qualifier, specifies the unit number you want associated with the network terminal. The default of 0 allows the TELNET software to select the next available unit number.

With the /DELETE_SESSION qualifier, specifies the unit number of the network terminal you want to delete.

Qualifiers

/AUTHENTICATE

Optional. Default: None.

Specifies that you want the TELNET session to use Kerberos features.

Note

The /AUTHENTICATE qualifier also can be used with the TELNET commands OPEN and CONNECT.

/BIND_SESSION *network_device*

Optional. Default: None.

Binds a TELNET terminal device to an existing network device. If the bind is successful, the DCL symbol \$TELNET_DEVICE contains the TNA device name.

/CREATE_SESSION

Optional. Default: None.

Specifies that TELNET should create a pseudo device (network terminal) and connect it to the specified remote port. For additional information, see the CREATE_SESSION command. You can use the following qualifiers with CREATE_SESSION:

- /NOTIMEOUT
- /TIMEOUT= *option*

Options include:

- -NOIDLE
- -IDLE= *delta_time_interval*

Specifies the delta time interval to wait with no activity before closing the connection. The general delta time format is *hh:mm:ss.cc*.

- -NORECONNECT
- -RECONNECT= *delta_time_interval*

Specifies the delta time interval to wait before retrying a connect request. The general delta time format is *hh:mm:ss.cc*.

- /PERMANENT Optional.

- `/PROTOCOL= option`

Optional. Default: NONE.

Options include:

- NONE

Data is sent with no interpretation (raw).

- NVT

Network Virtual Terminal (NVT), TELNET's internal representation of a standard network terminal. NVT format is standard 7-bit ASCII code transmitted in 8-bit octets, the canonical form of data representation used by both the client and the server.

- TELNET

Standard TELNET protocol.

- RLOGIN

Standard RLOGIN protocol.

`/DELETE_SESSION`

Optional. Default: None.

Specifies that TELNET should delete the specified pseudo device (network terminal). For additional information, see the `DELETE_SESSION` command.

`/FORWARD`

`/NOFORWARD`

Optional. Default: `/NOFORWARD`.

Forwards a copy of your Kerberos tickets to the remote host. The `/NOFORWARD` qualifier overrides any forwarding specified in your machine's configuration files. You must request forwardable tickets at the same time that you issue the `KINIT` command.

You must use the `/AUTHENTICATE` qualifier when you specify the `/FORWARD` qualifier.

`/LOG_FILE= file`

Optional. Default: No logging.

An optional log file that contains all session output. Using this option does not affect your terminal output. You cannot use this option for TN3270 sessions.

`/NOINTERACTIVE`

Optional. Default: TELNET command mode.

Disables the capability of using the escape character to leave a session and return to the TELNET prompt. This option is useful when the TELNET command is referenced in a command procedure in a captive account.

`/PORT= n`

Optional. Default: 23.

Remote port to which you want your TELNET process to connect. Use this qualifier only if you are connecting to a host that does not use the standard TELNET port.

`/REALM= realm-name`

Optional.

Requests Kerberos tickets for the remote host in the specified realm, instead of determining the realm itself.

You must use the `/AUTHENTICATE` qualifier when you specify the `/REALM` qualifier.

`/TERMINAL_TYPE= type`

Optional. Default: None.

The type of terminal to emulate. Enter the full specification for one of these terminals:

- IBM-3278-2
- IBM-3278-3
- IBM-3278-4
- IBM-3278-5
- VT100
- VT200
- VT300
- VT400
- VT500

`/UNBIND_SESSION network_device terminal_device`

Optional.

Unbinds a network device (BG x:) from a TELNET terminal device (TNA x:) that was initially bound by a `BIND_SESSION` command or qualifier.

Examples

1. `$ TELNET`
TELNET> **ENABLE DEBUG**
TELNET> **SET TERMINAL /DEVICE=VT300**
Terminal type is set to VT300
TELNET> **CONNECT DEBTS**

In this example, the TELNET command performs the following actions:

- Starts TELNET.

- Customizes the environment.
 - Establishes a connection to host DEBTS and sets up the terminal type as VT300.
2. `$ TELNET MYCOM /TERMINAL_TYPE=IBM-3278-2`
Establishes a TELNET connection to remote host MYCOM and runs TN3270.
 3. `$ TELNET 130.180.5.5`
Establishes a TELNET connection to the host at IP address 130.180.5.5.
 4. `$ TELNET UCOM 31`
Establishes a TELNET connection to remote host ucom at port 31.
 5. `$ TELNET/AUTHENTICATE/REALM=jet.mbs.com terse`
%TELNET-I-TRYING, Trying ... 15.21.308.11
%TELNET-I-SESSION, Session 01, host terse, port 23
%TELNET-I-ESCAPE, Escape character is ^]
terse.ucx.ttg.mbs.com

This example logs in to system terse with Kerberos credentials.

6. `$ TELNET/AUTHENTICATE/FORWARD terse`
%TELNET-I-TRYING, Trying ... 15.21.308.11
%TELNET-I-SESSION, Session 01, host terse, port 23
%TELNET-I-ESCAPE, Escape character is ^]
[Kerberos V5 accepts you as 'j_brown@terse.mbs.com']
[Kerberos V5 accepted forwarded credentials]

This example forwards credentials to host terse for user j_brown.

TN3270

TN3270 — Starts a TELNET session that runs TN3270 and does one of the following: displays the TELNET prompt or establishes a connection to a remote host.

Syntax

```
TN3270 [ host ]  
    [ /CHARACTER_SET=file ]  
    [ /KEY_DEFINITIONS=file ]  
    [ /NATIONAL_CHARACTERS=char_set ]  
    [ /NOINTERACTIVE ]  
    [ /PORT=n ]  
    [ /PRINTER=file ]  
    [ /STATUS=state ]  
    [ /TERMINAL_TYPE=IBM-3278-n ]
```

Parameter

host

Optional.

Remote host to which you want to connect. Specify one of the following:

- Host name
- IP address

Qualifiers

`/CHARACTER_SET= file`

Optional. Default: ORIGINAL.

File with the EBCDIC-to-DMCS and the DMCS-to-EBCDIC translation tables.

If you omit this qualifier, TN3270 does the following:

- Uses the translation table named by the default file `SYSLIBRARY:TN3270DEF.TBL`, if your system manager has created it.
- Defaults to its own translation table if `TN3270DEF.TBL` does not exist. The default table maps the EBCDIC set to the equivalent DMCS characters.

If none of these translation tables meets your needs, the system manager can generate a new translation table. (For information about the EBCDIC-to-DMCS translation tables, refer to the *VSI TCP/IP Services for OpenVMS Management* manual.)

Note

To reset the default, do not abbreviate ORIGINAL.

`/KEY_DEFINITIONS= file`

Optional. Default: default keyboard layout.

Keyboard definition file you created to redefine how the TN3270 key functions correspond to your keyboard layout. This file holds the definitions for alternative keyboard mapping.

`/NATIONAL_CHARACTERS= character_set`

Optional. Defaults: For 8-bit terminals: MULTINATIONAL

For 7-bit terminals: US_ASCII.

National Replacement Character Set (NRCS) for which your terminal is configured. Specify one of the following:

| | |
|----------|---------------|
| Canadian | MULTINATIONAL |
| Dutch | Norwegian |
| Finnish | Spanish |
| French | Swedish |
| German | Swiss |
| Italian | UK_ASCII |
| Japanese | US_ASCII |

`/NOINTERACTIVE`

Optional. Default: TELNET command mode.

Disables the capability of using the escape character to leave a session and return to the TN3270 prompt. This option is useful when the TN3270 command is referenced in a command procedure in a captive account.

`/PORT= n`

Optional. Default: 23.

Remote port to which you want your TELNET/TN3270 process to connect. Use this qualifier only if you are connecting to a host that does not use the standard TELNET port.

`/PRINTER= file`

Optional. Default: TN3270PRINT.LIS.

File that records your screen's contents when you use the PRINT function.

Directs printer output to either a file or a spooled printer (not a physical printer or terminal).

`/STATUS= state`

Optional. Default: AUTOMATIC.

Determines how the status line operates during your session. Specify one of the following:

| | |
|-----------|--|
| AUTOMATIC | Status line is displayed. The status line is disabled automatically if the remote host writes data to the area under the status line, or if you type in that space. The status line is restored automatically when the data is erased. |
| ON | Status line is always displayed. |
| OFF | Status line is not displayed. |

To toggle between ON and OFF, invoke the STATUS function.

`/TERMINAL_TYPE=IBM-3278- n`

Optional. Default: IBM-3278-2.

IBM terminal to emulate. Enter the full specification for one of the following:

- IBM-3278-2
- IBM-3278-3
- IBM-3278-4
- IBM-3278-5

Examples

1. \$ TN3270 MYCOM

Establishes a TELNET connection to remote host MYCOM. By default, the physical terminal functions as an IBM-3278-2 model terminal.

2. \$ TN3270 130.180.5.5 /TERMINAL_TYPE=IBM-3278-3 - _\$_ /KEY_DEFINITIONS=MY_NUMPAD.FIL

Establishes a TELNET connection to the host at IP address 130.180.5.5. The terminal functions as if it were an IBM-3278-3 model terminal, and it uses the customized keyboard definition file MY_NUMPAD.FIL.

3. \$ TN3270 UCOM 31 /TERMINAL_TYPE=IBM-3278-5 /PRINTER=LOG

Establishes a TELNET connection to remote host ucom:

- The connection is at port 31 on ucom.
- The terminal is functioning as if it were an IBM-3278-5 model terminal.
- During the session at ucom, using the PRINT function records the screen's contents in a file named LOG.LIS.

UNBIND_SESSION

UNBIND_SESSION — Unbinds a network device (BG x:) from a TELNET terminal device (TNA x:) that was previously bound with a BIND_SESSION command or qualifier.

DCL Syntax

UNBIND_SESSION *network_device terminal_device*

Parameter

network_device

Required.

Network device (BG x:) to unbind.

terminal_device

Required.

Associated terminal device (TNA x:).

Example

```
TELNET> SHOW DEVICE
TNA458:  BG2032:  Temporary condor:4009          angel:23
TNA460:  BG4739:  Temporary condor:23          ler13.dec.com:1037
TNA463:  Temporary
TELNET> UNBIND_SESSION BG2032:  TNA458:
```

TELNET>

This example displays the devices and unbinds one of them.

Chapter 5. Sending and Receiving Mail Using SMTP

For exchanging electronic mail (e-mail) with users working on internet hosts, the TCP/IP Services product includes Simple Mail Transfer Protocol (SMTP), Post Office Protocol (POP) software, and Internet Message Access Protocol (IMAP).

The following table lists the SMTP electronic mail services you can perform and the sections that explain how to use them.

| Capability | Section |
|---|---------|
| Send mail to users on other internet hosts. | 5.2 |
| Specify an SMTP outbound alias. | 5.3 |
| Send mail to multiple users, with and without distribution lists. | 5.4 |
| Read mail. | 5.5 |
| Set a "personal" name. | 5.6 |
| Create a carbon copy of your messages. | 5.7 |
| Forward messages to other users. | 5.8 |
| Forward files to other users. | 5.9 |
| Use the UNIX-to-UNIX Copy Program (UUCP) to send mail. | 5.10 |
| Get status information about SMTP mail. | 5.11.1 |
| Remove holding-state mail messages from SMTP queues. | 5.11.2 |
| Requeue holding-state mail messages for delivery. | 5.11.3 |
| Use your PC mail software to receive and send messages. | 5.12 |

To use TCP/IP mail services, you need the following:

- Knowledge of the OpenVMS Mail utility
- User names and host names or IP addresses of the people to whom you want to send mail

5.1. Obtaining Online Help

You can obtain online help for TCP/IP Services electronic mail by entering the following command:

```
$ HELP TCPIP_SERVICES SMTP
```

5.2. Sending Mail

To send mail to another internet host also running SMTP, simply invoke the OpenVMS Mail utility at the DCL prompt, type SEND at the MAIL> prompt, and enter the destination. A remote destination

consists of the destination user name followed by an at sign (@) and the destination host (such as *user_name@host*). If the user is on your local host, omit the at sign and host name.

Specify the destination host as either a host name or an IP address. The following example sends mail to user MALCOLM at host PHILOS.BU.EDU:

```
$ MAIL
MAIL> SEND
To: malcolm@philos.bu.edu
Subj: Final Exams
```

The following example sends mail to user MALCOLM at a host with IP address 16.20.40.59. Note that the IP address can be enclosed within brackets.

```
$ MAIL
MAIL> SEND
To: malcolm@16.20.40.59
Subj: Final Exams
```

The OpenVMS Mail utility automatically detects destination addresses that include fully qualified host names (one in which the node component includes a period [.] , such as MALCOLM@PHILOS.BU.EDU) and sends the mail using the SMTP protocol, unless your system has been set up to use a different Internet protocol (by defining an alternate protocol with the MAIL \$INTERNET_TRANSPORT logical name).

However, if you use a destination address that is not fully qualified — that is, one in which the node component does not include a period (.) — the Mail utility by default assumes the address is a DECnet address. For example, if you specified MALCOLM@PHILOS as the destination address, the Mail utility converts it to DECnet format (PHILOS::MALCOLM).

You can force the OpenVMS Mail utility to use a specific protocol by defining the MAIL \$INTERNET_MODE logical name. This is useful in cases where a mail address, such as MALCOLM@PHILOS, can be valid for either SMTP or DECnet.

You can assign one of the following values to the MAIL\$INTERNET_MODE logical name:

- SMTP

OpenVMS Mail always interprets the node component of an unqualified address as an Internet address specification. (SMTP is the default mode unless you define an alternate Internet transport with the MAIL\$INTERNET_TRANSPORT logical name.)

- DECNET

OpenVMS Mail always interprets the node component of an unqualified address as a DECnet node specification.

- HYBRID (the default)

OpenVMS Mail uses an Internet protocol if the node component of the address contains a period. If no periods are in the node component, Mail uses the DECnet protocol.

Define the logical name in your LOGIN.COM file. For example, the following definition causes the Mail utility to interpret any address that does not include a period in the node component of the specification as an Internet address:

```
$ DEFINE MAIL$INTERNET_MODE SMTP
```

Another way to force the OpenVMS Mail utility to use SMTP is to include the SMTP% prefix immediately before the destination or IP address. Enclose the destination in quotation marks, as in the following example:

```
$ MAIL
MAIL> SEND
To: SMTP% "malcolm@philos"
```

To prevent the OpenVMS Mail utility from automatically converting an unqualified Internet host name address to a DECnet format, you can do one of the following:

- Fully qualify the host name (for example, specify the destination address as MALCOLM@PHILOS.BU.EDU instead of MALCOLM@PHILOS).
- Define the MAIL\$INTERNET_MODE logical name as SMTP.
- Include the SMTP% prefix before the destination address.

For more information about the OpenVMS Mail utility and how it interprets addresses, see the appropriate OpenVMS documentation.

5.3. Specifying the SMTP Outbound Alias

SMTP allows you to specify an outbound alias that is applied to mail as it is sent and also specifies the network address to which a reply is sent.

5.3.1. Defining the Outbound Alias

To specify an outbound alias, define the TCPIP\$SMTP_FROM logical to the text you want your From: header to be.

For example, you might define the logical as follows:

```
$ DEFINE TCPIP$SMTP_FROM "bill.smith@xxx.com"
```

This command sets the outbound alias to the following:

```
From: bill.smith@xxx.com
```

Define the TCPIP\$SMTP_FROM logical before invoking OpenVMS Mail.

If you always want the header to be sent with the outbound alias, define the logical in your login command procedure (LOGIN.COM).

The outbound alias must be a valid address to which recipients can reply. If it is not valid, recipients cannot reply to you, and bounced mail messages are not returned to you.

If you do not define the TCPIP\$SMTP_FROM logical, the From: address on your mail messages is the same one that you have always had.

Use only simple 7-bit ASCII characters in the value you assign to the TCPIP\$SMTP_FROM logical. Do not use control characters.

The address you use to define TCPIP\$SMTP_FROM must be an RFC 822 legal SMTP address; that is, *user@domain*. If the address is not interpreted correctly, the SMTP mailer ignores it and uses the From: address that it has constructed for you.

5.3.2. Appending the Personal Name String to the Outbound Alias

If you have defined an OpenVMS Mail personal name, the SMTP mailer appends that string to the outbound alias.

For example, a personal name might look like the following:

```
Bill L. Smith Phone: 123-456-8000
```

The TCPIP\$SMTP_FROM logical is defined as follows:

```
$ DEFINE TCPIP$SMTP_FROM "bill.smith@xxx.com"
```

The following example shows the resulting From: header:

```
From: bill.smith@xxx.com (Bill L. Smith Phone: 123-456-8000)
```

The personal name is appended to the From: address only if both of the following conditions are met:

- The value you give for the TCPIP\$SMTP_FROM logical does not contain parenthetical phrases (text within parentheses).
- The From: address contains the SMTP domain string (the @ domain portion of the address).

To use a different personal name than the one defined in your OpenVMS Mail personal name, define the personal name string as part of the TCPIP\$SMTP_FROM logical in a parenthetical phrase after the *user@domain* address. Separate the address from the parenthetical phrase with a space. Do not use double quotation marks (" ") in the personal name.

For example, you can define the outbound alias logical as follows:

```
$ DEFINE TCPIP$SMTP_FROM -  
_ $ "bill.smith@xxx.com (Phone: 123-456-8000 FAX: 123-456-9000)"
```

Note the following restrictions:

- The SMTP mailer does not allow you to define the TCPIP\$SMTP_FROM logical using the following syntax:

```
"personal-name" <user@host>
```

- Do not specify the logical as follows:

```
$ DEFINE TCPIP$SMTP_FROM ""personal-name" <bill.smith@xxx.com>"
```

Instead, define the logical as follows:

```
$ DEFINE TCPIP$SMTP_FROM "bill.smith@xxx.com (personal-name)"
```

5.3.3. Appending a Substitute Domain String

If you define TCPIP\$SMTP_FROM without an SMTP domain string (the @ domain portion of the address), SMTP appends the substitute domain name to the text you define. If you do not define a substitute domain name, the host name is used.

For example, the host is configured with a substitute domain name of `x.com`, and the `TCPIP$SMTP_FROM` logical is defined as follows:

```
$ DEFINE TCPIP$SMTP_FROM "bill.smith"
```

In this case, the resulting address is as follows:

```
From: bill.smith@x.com
```

However, if the host is not configured with a substitute domain and the host name is `host.x.com`, `SMTP_FROM` is defined as follows:

```
$ DEFINE TCPIP$SMTP_FROM "bill smith"
```

In this case, the resulting address is as follows:

```
From: bill.smith@host.x.com
```

5.3.4. Disabling Modifications to `TCPIP$SMTP_FROM`

To disable the modifications that TCPIP SMTP makes to the value you assign to `TCPIP$SMTP_FROM` (such as appending the OpenVMS personal name and *@ domain* to a value with no *@ domain*), include the string `[VERBATIM]`.

For example:

```
$ DEFINE TCPIP$SMTP_FROM "[VERBATIM] bill.smith@xxx.com"
```

The resulting address is as follows:

```
From: bill.smith@xxx.com
```

5.3.5. `TCPIP$SMTP_FROM` and the Return-Path: Header

The address you define is used for the `Return-Path:` mail header. The `Return-Path:` header is used to bounce undeliverable mail. Note that the version of the text used for the `Return-Path:` header is stripped of comments (such as the personal name string) and always has a domain string. For more information about the domain name that is supplied, see Section 5.3.3.

5.3.6. X-VMS-True-From: Header

When the `TCPIP$SMTP_FROM` logical is used to set the `From:` header, the text that would normally have been used for the `From:` header is added to the headers as an `X-VMS-True-From:` header.

5.3.7. Managing Outbound Alias Processing

To disable outbound alias processing and use of the `TCPIP$SMTP_FROM` logical, define the following system logical:

```
$ DEFINE/SYSTEM TCPIP$SMTP_PROHIBIT_USER_HEADERS 1
```

5.4. Sending Mail to Multiple Users

To send mail to more than one user at a time, use the SEND command as discussed in Section 5.2, and type one of the following at the To: prompt:

- A list of names (Section 5.4.1)
- The name of an existing distribution list (Section 5.4.2)

5.4.1. Entering a List of Names

When you type a list of names, use the following guidelines:

- Separate the names with a comma (,).
- If multiple users are on the same remote host, type the full *user_name@host* combination for each user.
- If a user is on your local host, omit the at sign (@) and host name.

For example:

```
MAIL> SEND
To: user1,user2,user3@host3,user4@host4
```

In the preceding example, *user1* and *user2* are located on the local OpenVMS system; *user3* is located on *host3*; and *user4* is located on *host4*.

```
MAIL> SEND
To: user1@host5,user2@host5
```

In the preceding example, both *user1* and *user2* are located on remote host *host5*.

The following example sends the same mail to the following users:

- Users NOWAK and BRENT on host CENTRAL.GREEN.ORG
- User MILLER on host BOSTON.GREEN.ORG

```
MAIL> SEND MEETINGS.TXT
To: NOWAK@CENTRAL.GREEN.ORG,BRENT@CENTRAL.GREEN.ORG,
MILLER@BOSTON.GREEN.ORG
Subj: SCHEDULE AND AGENDAS
```

5.4.2. Distribution Lists

To send mail to multiple users by entering the name of a distribution list, follow these guidelines:

- The file with the distribution list can be yours or belong to someone else.
- The file can reside locally or remotely.
- Do not include the names of other distribution lists in the distribution list.

You can use two kinds of distribution lists:

- OpenVMS distribution list

- Create a .DIS file in your own directory or use an existing one.
- You can include comment lines (lines preceded by an exclamation mark [!]) in the .DIS list file.
- You can include both OpenVMS addresses and SMTP addresses. If you want the OpenVMS Mail utility to use SMTP for all SMTP addresses, qualified and unqualified, either set the MAIL\$INTERNET_MODE logical name to SMTP, specify fully qualified SMTP addresses only, or use the SMTP% prefix with the destination enclosed in quotation marks.
- To send mail to the people on your distribution list, enter the following command:

```
MAIL> SEND
To: @list_name
```

- SMTP distribution list

- Use an existing .DIS file or create a .DIS file in SYSS\$SPECIFIC:[TCPIP\$SMTP] or, if defined on your system, TCPIP\$SMTP_COMMON:.
- Give the list a unique name that is not the same as a local user name.
- To specify comment lines, use an exclamation mark (!) in the first column.
- Include only SMTP addresses.
- Use one address per line.
- To send mail to the people on this distribution list, enter the following command:

```
MAIL> SEND
To: list_name@host_where_list_resides
```

If the MAIL\$INTERNET_MODE logical name is not set to SMTP, either specify a fully qualified host name or use the SMTP% prefix.

The following examples show different methods of using distribution lists.

1. This example sends mail to users whose names are on the local OpenVMS distribution list AGENCIES.DIS. The distribution list file is displayed in this example. The MAIL\$INTERNET_MODE logical name is not set, so by default unqualified Internet addresses would be sent over DECnet; therefore, the AUDUBON@NY address is included with the SMTP% prefix and quotation marks.

```
$ TYPE AGENCIES.DIS
```

```
!
! This is an OpenVMS distribution file named AGENCIES.DIS.
!
SMTP%"audubon@ny"
WILLIAMS@BELTWAY.ORG
WILDLIFE@DALLAS.ORG
jmuir@19.8.7.6
```

```
SEC@GP.INTER8.ORG
BATES::SCOPE
!
$ MAIL
MAIL> SEND
To: @AGENCIES.DIS
Subj: NEWS TO WATCH FOR
```

2. This example sends mail to users whose names are on the local SMTP distribution list SYS \$SPECIFIC:[TCPIP\$SMTP]NATL_INTEREST.DIS. The distribution list file is displayed in this example.

```
$ TYPE NATL_INTEREST.DIS

green@19.8.7.6
wlf@19.7.6.5
arlo@19.4.3.2
free::monicaL
wendell@biolo.ne.edu
$ MAIL
MAIL> SEND
To: natl_interest@main_office.org
Subj: News Items
```

3. This example sends mail to the users on SMTP distribution list FINANCE_CENTERS.DIS, which is maintained on remote mail server host HOLBROOK.

```
$ TYPE FINANCE_CENTERS.DIS

ny_accts@23.9.7.4
sf_stocks@23.7.11.2
dallas_pfs@23.1.5.1
denver_accts@holbrook
$ MAIL
MAIL> SEND
To: finance_centers@holbrook
Subj: Portfolio Activity
```

5.5. Reading Mail

To read received mail, follow these steps:

1. At the DCL prompt, type MAIL.
2. At the MAIL> prompt, enter the DIRECTORY command to view a list of received messages.
3. Enter the READ command or indicate the message number you want to view in exactly the same way as you would for OpenVMS mail.

In the following example, a user views the directory of unread new mail and selects message 3 to read.

```
$ MAIL
```

```
You have 3 new messages.
```

```
MAIL> DIRECTORY
NEWMAIL
```

```
# From           Date           Subject
1 GWAY::SMTP%"helenm@bhc 10-MAR-2001  Just Checking In
2 GWAY::SMTP%"mays@sfg 11-MAR-2001  Common Bases
3 CBIRD::SMTP%"seaway 12-MAR-2001  Cruises
```

```
MAIL> 3
```

5.6. OpenVMS Mail Personal Name String

You can define a personal name string that is included at the top of the mail messages you send. To create a personal name with SMTP mail, use the SET PERSONAL_NAME command. Note the following restrictions:

- Enclose the string in double quotation marks.
- Do not use additional double quotation marks within the string.
- You can use single quotation marks (' ') within the personal name.
- Do not use 8-bit ASCII characters (for example, ä or ö). The eighth bit is truncated. For example, ä becomes d and ö becomes v.

The following command sets a personal name that includes quotation marks:

```
$ MAIL
MAIL> SET PERSONAL_NAME "'Wealth' is in the mind"
```

5.7. Carbon-Copying Messages

You can enable carbon copying by using the SET CC-PROMPT command. Follow these guidelines when you specify destinations for the CC : prompt:

- Follow the OpenVMS Mail conventions for copying mail to other people or to yourself.
- To enter the correct address, follow the guidelines listed in Section 5.2.

The following example sends mail to user AL and copies to users ROLLINS, BOND, and RICH:

```
MAIL> SEND
To:  al@airways
CC:  rollins,bond,rich@flight_central.com
Subj: Directions for Night Flight
```

In the following example, OpenVMS user BRODIE sends mail to UNIX user owens and copies soltau.

```
MAIL> SET CC_PROMPT
MAIL> SEND
To:  owens@kezar
CC:  soltau@fgtoo.bonkers.org
Subj: Goals for the Week
```

Enter your message below. Press CTRL/Z when complete, or CTRL/C to quit:

```
RC: Let's get a jump on the ball this time.  
We'll meet before the conference to organize.  
- J.B.  
Ctrl/Z
```

5.8. Forwarding Messages

You can forward any mail you receive to any internet host. Follow the OpenVMS Mail conventions for forwarding mail.

5.9. SMTP SFF (Send From File)

SMTP allows you to create a mail message in a file and send it to the SMTP mailer to be delivered with headers you specify. Using this feature, you can create automated tools that compose and send mail messages. It is also useful for forwarding non-text files (MIME), because it prevents the mailer from encapsulating the MIME and SMTP headers in the body of a new mail message. Thus, SMTP can function like the `redirect` command on your personal computer, which simply takes the message as is, without encapsulating it in another message, and sends it to the person you name.

To redirect a MIME mail message without encapsulation so that it is readable to the receiver, follow these steps:

1. From OpenVMS MAIL, use EXTRACT/NOHEADER to extract the mail message.
2. Exit the MAIL program.
3. Modify the file to include the SMTP commands. For example, put the address of the recipient into the RCPT TO: <> line. For more information about the SFF format, see Section 5.9.1.
4. Send the file to SFF.

If you want headers like From:, To:, or Message-ID:, you must include them in the file. SFF adds only the Received: header, as described in Section 5.9.3.

5.9.1. Format of the SFF File

You can use SFF to send a text file that complies with RFC 822 by including commands (as described in RFC 821) preceding the RFC 822 message. MIME, by definition, complies with RFC 822; therefore, MIME mail can be delivered using SFF.

For example:

```
$ TYPE TEST_SMTP_SFF.TXT  
MAIL FROM:  
<green@abc.com>  
RCPT TO:  
<green@abc.com>  
DATA  
Date: Sun, 4 Aug 1996 14:48:14 -0400  
Message-Id:  
<96080414481486@abc.com>
```

From: green@abc.com (Charly Green - ABC-Corp engineering)
To: green@abc.com
Subject: Test of SFF mechanism

This is the message text.

The SMTP protocol commands specify:

1. The return path of the mail
2. The recipients
3. The DATA command
4. The RFC 822 message

The commands that precede the RFC 822 messages must appear in the file in the order listed above. The MAIL FROM and RCPT TO commands form the “envelope,” as described in RFC 821 and summarized as follows:

1. The MAIL FROM command specifies the address to which the mail is bounced if necessary. There must be one and only one MAIL FROM command.

You can specify a blank MAIL FROM command. For example:

```
MAIL FROM: <>
```

2. The RCPT TO command specifies the address of a recipient. There must be at least one RCPT TO command but there can be more, one for each recipient.

Do not specify a blank RCPT TO command.

Each RCPT TO command must occupy a separate line and may contain only one address. If the mail is to go to multiple addresses, include one RCPT TO command for each address.

3. The DATA command follows the last RCPT TO command; it flags the end of the RCPT TO commands and the beginning of the header block. The DATA command is required.

Do not include a Return-Path header in the RFC 822 headers. If the mail is to be delivered locally, SMTP includes a Return-Path header based on the MAIL FROM command. If the mail is relayed to another SMTP host, the return path is determined by the MAIL FROM command on the final destination host.

5.9.2. SFF File Requirements

The mail message file can be in either of the following formats:

- Variable length

This type of file does not require carriage-return/line-feed characters at the end of each line.

- Stream_LF

This type of file requires at least a line-feed character at the end of each line. It is not necessary to add carriage-return characters.

5.9.3. SFF Security Measures

The ability to create messages with arbitrary headers could be used to spoof message headers. To limit this, the SFF mechanism adds a Received: header to the headers you supply. This tells you the origin of an attempted spoofed message.

You can invoke SFF from an application or from DCL, as described below.

5.9.4. Invoking SFF from an Application

TCPIP\$SMTP_MAILSHR.EXE contains a routine called TCPIP\$SMTP_SEND_FROM_FILE. This routine is declared as follows:

```
unsigned int TCPIP$SMTP_SEND_FROM_FILE(infile_name, logfd, log_level)
char *infile_name;
FILE *logfd;
int log_level;
```

The arguments for this routine are:

- *infile_name*
Specifies the name of the text file that contains the RFC 822 mail message and SMTP protocol information.
- *logfd*
Specifies the file to which to log diagnostic messages. This file must be opened by the caller before calling this routine. If no log file is specified, output goes to SYS\$OUTPUT. This argument is optional.
- *log_level*
Specifies the level of diagnostics to use: either 1 (on) or 0 (off). The default is 0 (off). This argument is optional.

To call the routine, link with TCPIP\$SMTP_MAILSHR.EXE/SHARE.

5.9.5. Invoking SFF from DCL

The SMTP_SFF command allows you to invoke SFF. To define SMTP_SFF as a foreign command so that you can use it from DCL, enter the following command:

```
$ SMTP_SFF::=$TCPIP$SYSTEM:TCPIP$SMTP_SFF.EXE
```

This command takes UNIX style parameters and passes them to SFF.

The command format is:

```
SMTP_SFF infile_name [-log logfile_name] [-loglevel log_level]
```

Where the parameters to this command are:

- *infile_name*

Specifies the name of the text file that contains the RFC 822 mail message and SMTP protocol information.

- *logfile_name*

Specifies the name of the log file for diagnostic messages. (The default is SYSS\$OUTPUT.)

- *log_level*

Specifies the debug log level: either 1 (on) or 0 (off). (The default is 0 (off).)

5.10. Routing Mail with the UNIX-to-UNIX Copy Program

The UNIX-to-UNIX Copy Program (UUCP) lets a system copy files to and from other systems running UUCP. UUCP is usually used to copy files over a dialup connection (see Section 5.10.1).

To route mail using UUCP, ask your system manager to define the general gateway in the SMTP configuration.

To use SMTP to route mail to a system running UUCP, address the mail as follows:

```
MAIL> SEND
To: SMTP%"user_name!uucp_host"
```

The following example sends mail to *geoffrey* at host *haldir*:

```
$ MAIL
MAIL> SEND
To: SMTP%"geoffrey!haldir.of.com"
```

5.10.1. Dialup Connections

Ask your system manager whether you need to specify a gateway host in mail addresses when you work on UUCP dialup lines.

The following example sends mail during a dialup connection by specifying a gateway host:

```
MAIL> SEND
To: gateway_host!crandle!watts
CC: billw,jenny,ibis
Subj: Events Schedule
```

5.11. Management Commands for Mail

Table 5.1 describes the management commands you can use to work with SMTP mail messages currently in a queue. Type these commands at the TCP/IP> prompt.

Table 5.1. Commands for Using SMTP

| Command | Function |
|-----------|---|
| SHOW MAIL | Displays information about mail messages queued to your process' user name. |

| Command | Function |
|-------------|---|
| REMOVE MAIL | Deletes mail messages that are in a holding state in SMTP queues. |
| SEND MAIL | Releases for delivery a mail message that is in a holding state. |

The following sections describe how to use these commands. For full command descriptions, refer to the *VSI TCP/IP Services for OpenVMS Management Command Reference*.

5.11.1. Displaying SMTP Mail Status Information

Use the SHOW MAIL command to display the following information about SMTP mail:

- Message (entry) number of the queued mail
- User name of the sender (to display information about other users, you need SYSPRV or BYPASS privilege)
- File name of the queued mail
- Status of a message

The following examples show how to display SMTP mail status information.

1. The following command displays information about message 826 in an SMTP queue. By default, the command returns brief information. Specify /FULL for more detailed information, as shown in example 2:

```
$ TCPIP SHOW MAIL /ENTRY=826
```

```
SMTP Mail Queue Entry   826      User: MARLOW
File: _PLUTO$DKD0:[MARLOW]970207015114579_MARLOW.TCPIP_PLUTO;1
Status: Processing
```

2. The following command displays detailed information about all your mail. The /RECIPIENT qualifier, used with the /FULL qualifier, displays selected classes of information, depending on the option you specify:

| Option | Description |
|--------|---|
| ALL | Shows failed, sent, and unsent messages. |
| FAILED | Shows messages that could not be read for a particular recipient. |
| SENT | Shows successful deliveries to a particular recipient. |
| UNSENT | Shows messages that as yet are unsent. |

```
$ TCPIP
TCPIP> SHOW MAIL /FULL /RECIPIENT=ALL
```

```
SMTP Mail Queue Entry:   826      User: MARLOW
File: _PLUTO$DKD0:[MARLOW]970207015114579_MARLOW.TCPIP_PLUTO;1
Status: Processing
```

Message Destinations:

Address: marlow@pluto

Message Headers:

Return Path: ???

SMTP Mail Queue Entry: 828 User: MARLOW
File: _PLUTO\$DKD0:[MARLOW]970207015114580_MARLOW.TCPIP_PLUTO;1
Status: Holding

Message Destinations:

Address: marlow@pluto

Message Headers:

Return Path: ???

5.11.2. Deleting Holding State Mail Messages from SMTP Queues

The following examples show how to delete mail messages from SMTP queues using the TCP/IP command REMOVE (similar to the DCL command DELETE/ENTRY).

Note

Use this command only to release mail messages that are being held; do not use this command to delete mail messages in the processing state.

1. The following command deletes mail message 828, a message that is holding (the message corresponds to your process's user name, or you have SYSPRV or BYPASS privileges). You are prompted to confirm that you want the message deleted.

```
$ TCPIP REMOVE MAIL /ENTRY=828  
_PLUTO$DKD0:[MARLOW]970207015114580_MARLOW.TCPIP_PLUTO;1? y
```

2. The following command removes all messages for your process's user name, or deletes everything in the SMTP queue if you have either SYSPRV or BYPASS privilege. The /NOCONFIRM qualifier prevents TCP/IP Services from prompting you for confirmation. Before deletion, TCP/IP Services copies this queued mail to the specified directory.

```
$ TCPIP REMOVE MAIL /NOCONFIRM /COPY=[MARLOW.OLD_MAIL]
```

5.11.3. Releasing Holding State SMTP Mail Messages for Delivery

The following example shows how to requeue an SMTP mail message that is currently holding, using the TCP/IP command SEND MAIL (similar to the DCL command ENTRY/RELEASE). You are prompted to confirm that you want the mail message requeued.

```
$ TCPIP SEND MAIL /ENTRY=828  
_PLUTO$DKD0:[MARLOW]970207015114580_MARLOW.TCPIP_PLUTO;1? y
```

5.12. Using Mail on Your PC

You can use either the Post Office Protocol (POP) or the Internet Message Access Protocol (IMAP) to access OpenVMS mail from your PC.

5.12.1. POP

With SMTP and the Post Office Protocol (POP) functionality, you can receive and send OpenVMS mail on your PC.

POP is a mail repository that accepts and stores your mail even when the PC is turned off. At your request, the POP server reads mail from your OpenVMS NEWMAIL folder, then moves the mail to your MAIL folder.

To send and receive mail on your PC, make sure the system manager has configured the POP server for use on your PC (the POP client system).

To set up your POP client account, use one of the following methods:

- On networks where maximum security is not required, enter your PC mail application and configure a user name and password into the system.

The user name and password pair becomes authorization information for the TCP/IP system, not your POP client system. Your PC client sends the password to the POP server unencrypted.

As an added security measure, POP permits only two user name and password authorization attempts per TCP connection.

- On networks where maximum security is required, enter your PC mail account and configure a user name and shared-secret password into the system.

This method is called the APOP authorization method. With this method, you store a shared-secret password in a one-line file named POP_SECRET.DAT in your default OpenVMS mail directory.

You can use the DCL command CREATE or your text editor to create the file and specify a password string, then set the file protection to prevent other users from accessing it. For example:

```
$ SET DEFAULT USER$DISK:[JONES.MAIL]
$ CREATE POP_SECRET.DAT
xyztancreff Ctrl/Z
$ SET FILE/PROT=(s,w,g,o:rwed) POP_SECRET.DAT
```

The shared-secret password cannot exceed 500 characters.

Each time you enter your PC mail application, the shared-secret string is sent from the PC client to the POP server using an encryption process.

For more information about the POP process, including information about how POP builds SMTP-compliant mail headers, refer to the *VSI TCP/IP Services for OpenVMS Management* guide.

5.12.2. IMAP

The IMAP server allows users to access their OpenVMS Mail mailboxes by clients such as Microsoft Outlook so that they can view, move, copy and delete messages. The SMTP server provides the extra functionality of allowing the clients to create and send mail messages.

For information about configuring and managing the IMAP server, refer to the *VSI TCP/IP Services for OpenVMS Management* guide.

5.12.2.1. How to Access Mail Messages Using IMAP

To access mail messages from the IMAP server, configure a user name and password into your client mail application. If an account is accessible without a password and a password is provided, the password is ignored.

In OpenVMS Mail, a user's mailbox file is, by default, named MAIL.MAI and resides in the user's default OpenVMS directory. In most cases, the user name to be configured is the user's OpenVMS account name.

An OpenVMS Mail user is allowed to have many mail files; a special syntax for the user name is defined so that the user can specify the set of mail files to be opened. This syntax is the user's OpenVMS account name followed by a percent sign and then partial file specifications of the mail files, each separated by a percent sign. Note the following:

- The file extension of .MAI is not required.
- The default MAIL.MAI file is assumed, but if the user adds it to the list, it will not be displayed twice.

In the following example, user SMITH has three mail files in a mail directory. One is the user's default MAIL.MAI file, and the others are ACCOUNTS.MAI and PRIVATE.MAI. The user name would be configured as follows in the IMAP client:

```
SMITH%ACCOUNTS%PRIVATE
```

Your client system opens the TCP connection and attempts to access the server by entering the IMAP LOGIN command with the configured user name and password. On successful connection, your mail files are the top level of mailboxes. In the preceding example, the mailboxes displayed will be Mail, Accounts, and Private. Unsuccessful attempts are logged in the event log file (described in the *VSI TCP/IP Services for OpenVMS Management* guide).

Once you have successfully connected to the IMAP server, a text file called TCPIP \$IMAP_MAILBOXES.DAT is created in your OpenVMS Mail directory. This file contains a record of the mailbox files that you specified, as well as a line-separated list of partial file specifications. Your mail directory and the .MAI file extension are appended to the partial file specification.

Note

When you change your default OpenVMS Mail directory with the OpenVMS Mail command SET MAIL_DIRECTORY, you must manually copy the TCPIP\$IMAP_MAILBOXES.DAT file from your old default directory to your new default directory to use the list of folders specified in the TCPIP\$IMAP_MAILBOXES.DAT file in the old directory. The OpenVMS Mail command SET MAIL_DIRECTORY is not aware of the TCPIP\$IMAP_MAILBOXES.DAT file and does not copy it from the old directory to the new one.

The next time you connect to the IMAP server, you can (optionally) remove percent signs and mailbox names from the user name field, because they are recorded permanently in the TCPIP \$IMAP_MAILBOXES.DAT file.

You can add extra mailbox names in a later connection. The TCPIP\$IMAP_MAILBOXES.DAT file is automatically updated.

The IMAP client software can create and delete mail files in your directory, either automatically, as in the creation of a "Deleted Items" mailbox, or as specified by the user.

The system manager can provide every user on the system with a preloaded tree of mailboxes by copying to each user's mail directory a preformatted copy of TCPIP\$IMAP_MAILBOXES.DAT.

5.12.2.2. OpenVMS Mail Configuration

Table 5.2 describes the way the OpenVMS Mail SET options affect the operation of IMAP.

Table 5.2. OpenVMS Mail SET options

| Option | Description |
|----------------|--|
| AUTO_PURGE | <p>IMAP clients have their own purge command, often called Compact or Compress. When a message is purged from a non-Wastebasket mailbox, it is put in the OpenVMS Mail Wastebasket. If the Wastebasket itself is purged, the messages are permanently deleted (equivalent to OpenVMS Mail PURGE), and disk space is then reclaimed as soon as the IMAP client disconnects. This occurs regardless of the AUTO_PURGE setting, which has no effect for an IMAP client.</p> <p>Any messages that are permanently deleted by an IMAP client briefly appear in your Wastebasket, but those messages are not visible from the IMAP client and are purged each time the client disconnects from that mail file.</p> |
| CC_PROMPT | Not applicable. |
| COPY_SELF | Not applicable. |
| EDITOR | Not applicable. |
| FILE | Not used. Instead, you can configure all mail files to be available simultaneously by setting the user name in the IMAP client configuration. You cannot copy or move messages between different mail files. |
| FOLDER | Not applicable. |
| FORM | Not applicable. |
| FORWARD | This is not applicable to the IMAP server, but setting a forwarding address results in messages being forwarded by OpenVMS Mail before being seen by the IMAP server. |
| MAIL_DIRECTORY | The directory, with an extension of .MAI, forms the partial file specification used to complete the file names of mail files using the values supplied as part of the user name in the IMAP client configuration. See Section 5.12.2.1 for details. |
| PERSONAL_NAME | Not applicable. |

| Option | Description |
|------------------|--|
| QUEUE | Not applicable. |
| SIGNATURE_FILE | Not applicable. |
| WASTEBASKET_NAME | This folder is always displayed by the IMAP client, even if it is currently empty. |

5.12.2.3. Mapping OpenVMS Mail Folder Names to IMAP Mailbox Names

OpenVMS Mail folders are presented to the IMAP client as IMAP mailboxes. All mailboxes are presented to the client in lowercase characters, beginning with an initial capital letter, and with capital letters following each space, at sign (@), opening parenthesis (“ ”), underscore (_), and hyphen (-).

The NEWMAIL folder requires special treatment. Because the IMAP protocol requires a top-level mailbox called Inbox, the NEWMAIL folder is mapped to Inbox. When the user opens the mailbox called Mail (which maps to file MAIL.MAI), the NEWMAIL folder is not listed so that the user is not confused by seeing the same folder listed twice.

OpenVMS Mail folder names are usually in all uppercase characters but can contain lowercase characters. Any lowercase characters are mapped to an underscore (_) followed by the character's uppercase equivalent. Underscores are mapped to double underscores (__), and dollar signs are mapped to double dollar signs (\$\$).

Table 5.3 shows the effects of folder-name mapping.

Table 5.3. OpenVMS Mail Folder-Name Mapping

| OpenVMS Mail Folder Name | IMAP Mailbox Name |
|--------------------------|-------------------|
| HELLO | Hello |
| Hello | H_e_l_l_o |
| HELLO-ALL | Hello-All |
| HELLO_ALL | Hello__All |
| HELLO\$ALL | Hello\$\$All |

5.12.2.4. Foreign Message Formats

The IMAP server determines the correct format for common file types. It does this by checking the beginning of the file for a recognizable file header that matches a set contained in the configuration file TCPIP\$IMAP_HOME:TCPIP\$IMAP_MAGIC.TXT (analogous to the magic files found on UNIX systems). If a matching file header is found, the server can let the client know the MIME type and subtype of the file.

Though most common file formats are included, it is possible to add other formats if the structure of the file header is known.

Table 5.4 describes the format of file-header recognition records.

Table 5.4. IMAP File-Header Recognition

| Field | Description |
|-------|---|
| Type | The type of the data to be tested. Possible values are: |

| Field | Description |
|---------|--|
| | <ul style="list-style-type: none"> • byte: A 1-byte value • short: A 2-byte value • long: A 4-byte value • string: A string of bytes • integer: An integer can be used indicating a number of bytes (30 or fewer) to allow for long matches. Examples in the configuration file are the two RIFF format files of WAVE and AVI. <p>Optionally, types can be followed by an ampersand (&) and a numeric value (mask), expressed in hexadecimal, to specify that the value is to be AND'ed with the numeric value before any comparisons are done. Examples in the configuration file are the two RIFF format files of WAVE and AVI.</p> |
| Test | <p>The value to be compared with the value from the file. The rules for the value depend on the type:</p> <ul style="list-style-type: none"> • Numeric type: The value is specified as octal or hexadecimal in the C programming language form where, for example, 013 is octal, and 0x13 is hexadecimal. • String type: The value is specified as a C programming language string with the usual escapes permitted (for example, n to indicate new line.) |
| Type | The Content-Type type to use in the MIME version of this message. |
| Subtype | The Content-Type subtype to use in the MIME version of this message. |
| Format | <p>Either “text” or “foreign,” indicating what sort of OpenVMS Mail message will be tested for this match. A test with “foreign” in this field is performed on messages only if they are sent using the /FOREIGN qualifier. Note that this implicitly advertises whether base64 or quoted-printable encoding will be used for a given bodypart type; base64 is used only if the message was sent using the /FOREIGN qualifier.</p> |

5.12.2.5. IMAP Message Headers

Mail message headers sent by the IMAP server must conform to the standard specified in RFC 822. Because many of the messages received on an OpenVMS system are not in the RFC 822, or

Internet, format (for example, DECnet mail or mail from another message transport system), the IMAP server builds a new set of headers for each message that is not RFC 822 format and is based on the OpenVMS message headers.

Table 5.5 describes the headers on mail messages that are forwarded by the IMAP server.

Table 5.5. Mail Message Headers

| IMAP Message Header | Obtained From |
|---------------------|---|
| Date: | Arrival date of message. Changed to Internet format, which shows the day of the week, the date, the time, and the time zone offset from Greenwich Mean Time (GMT). An example of the format is Wed, 30 May 01 16:19:53 +0100. |
| From: | OpenVMS Mail From: field. Rebuilt to ensure RFC 822 compatibility. (See Section 5.12.2.6.) |
| To: | OpenVMS Mail To: field. Rebuilt to ensure RFC 822 compatibility. (See Section 5.12.2.6.) |
| CC: | OpenVMS Mail CC: field. Rebuilt to ensure RFC 822 compatibility. (See Section 5.12.2.6.) |
| Subject: | OpenVMS Mail Subj: field. Accented characters are RFC 2047 encoded, but the change is not visible to users because IMAP clients reverse the encoding. |
| X-VMS-From: | OpenVMS Mail From: field. Not rebuilt. |
| X-IMAP4-Server: | Server host name and IMAP version information. Sent only if configuration option Send-ID-Headers is set to True. |
| X-IMAP4-ID: | Message UID. Sent only if configuration option Send-ID-Headers is set to True. |

The IMAP server sends these message headers to the IMAP client unless both of the following conditions are true:

- The configuration option Ignore-Mail11-Headers is set to True or is not defined. (See the *VSI TCP/IP Services for OpenVMS Management* guide.)
- The message text starts with SMTP headers.

5.12.2.6. OpenVMS Mail Address Fields

The IMAP server rebuilds the From: header. This header can be used as a destination address if a reply is requested from the IMAP client. The same is true for To: and CC: headers, if you request that a reply be sent to other listed recipients. Therefore, the IMAP server rebuilds these fields in compliance with RFC 822 before sending the header to the IMAP client.

Table 5.6 describes the different types of addresses that can appear in the OpenVMS Mail address fields.

Table 5.6. OpenVMS Mail Address Fields

| Address Type | Address Format |
|---|---|
| SMTP | SMTP%" <i>legal-address</i> ", where <i>legal-address</i> is an address that is compliant with RFC 822 and is commonly in the format <i>user@domain</i> . |
| DECnet | <i>node::username</i> |
| User name | <i>username</i> |
| DECnet address containing quotation marks | <i>node::"user@host"</i> |
| Cluster-forwarding SMTP address | <i>node::SMTP% "user@domain"</i> |

A host name is local if one of the following conditions is true:

- The host name is the same as the substitute domain specified in the SMTP configuration.
- The host name is found in the TCPIP\$SMTP_LOCAL_ALIASES.TXT file.

The following sections describe how IMAP rebuilds an address field for each type of address.

5.12.2.6.1. SMTP Address

The IMAP server uses the SMTP address within the quotation marks to rebuild the address field of an SMTP address. For example, message header

```
From: SMTP%" john.smith@federation.gov"
```

becomes:

```
From: john.smith@federation.gov
```

SMTP hides nested quotation marks by changing them to cent sign (¢) characters before passing them to OpenVMS Mail and then changing them back after a reply. The IMAP server removes any cent signs that designate double quotation marks. For example, the following message header:

```
From: SMTP%" ¢ABCMTS::MRGATE::¢ABCDEF::VIVALDI ¢¢@xyz.org"
```

becomes:

```
From: "ABCMTS::MRGATE::"ABCDEF::VIVALDI"@xyz.org"
```

5.12.2.6.2. DECnet Address

The value assigned to the configuration option Decnet-Rewrite defines how the IMAP server rebuilds a DECnet address. The following list describes the possible values:

- GENERIC

The entire address is changed to the SMTP format. For example, from host `widgets.xyzcorp.com`, the message header `From: ORDERS::J_SMITH` becomes:

```
From: "ORDERS::J_SMITH"@widgets.xyzcorp.com
```

In this example, instead of `widgets.xyzcorp.com`, the value of configuration option Gateway-Node (described in the *VSI TCP/IP Services for OpenVMS Management* guide) is used if it is defined; if not, the value of the SMTP substitute domain is used. Only if both of these options are undefined is the host name `widgets.xyzcorp.com` used.

- NONE

The `From:` line is sent unmodified to the IMAP client. For example:

```
From: ORDERS::J_SMITH
```

You cannot reply to this type of message from an IMAP client because the SMTP server does not accept an address in this form.

- TRANSFORM

The IMAP server attempts to translate the DECnet node name to a TCP/IP host name. If the name can be translated, the IMAP server checks whether the translated host name is local. If so, the `From:` header becomes an address in the format `user@ substitute-domain`. If not, the `From:` header becomes an address in the format `user@ hostname`. Note that the IMAP and SMTP servers call the same routine to determine whether a host name is local.

The following examples show some ways the IMAP server translates DECnet node names to TCP/IP node names. In these examples:

- The local host name is `orders.acme.widgets.com`.
- ORDERS translates the name to `"orders.acme.widgets.com"`.
 - The message header `From: ORDERS::J_SMITH` becomes:

```
From: j_smith@orders.acme.widgets.com
```
 - For a substitute domain of `acme.widgets.com`, the message header `From: ORDERS::J_SMITH` becomes:

```
From: j_smith@acme.widgets.com
```
 - If HOST12 translates to `host12.acme.widgets.com`, which is not local on host name `orders.acme.widgets.com`, the message header `From: HOST12::J_SMITH` becomes:

```
From: j_smith@host12.acme.widgets.com
```
 - If HOST13 does not translate and host `orders.acme.widgets.com` has no substitute domain defined, the message header `From: HOST13::J_SMITH` becomes:

```
From: "HOST13::J_SMITH"@orders.acme.widgets.com
```

In this example, if the configuration option `Gateway-Node` is defined, then its value is used instead of `orders.acme.widgets.com`.

5.12.2.6.3. User Name-Only Address

If the address under consideration is a recipient address, and the `From:` address is a DECnet address, then the recipient address is prefixed with the same routing information as that of the `From:` address. Then it is processed as if it were a DECnet address, as shown in Section 5.12.2.6.2.

Otherwise, the IMAP server appends the at sign (`@`) to the user name, and then appends one of the following, in order of preference:

- The value of configuration option `Gateway-Node`, if defined

- An SMTP substitute domain, if defined
- The local host name

For example, with an SMTP substitute domain defined as `acme.widgets.com`, the message header `From: Smith` becomes:

```
From: smith@acme.widgets.com
```

5.12.2.6.4. DECnet Address That Contains Quotation Marks

The values assigned to the configuration option `Quoted-Decnet-Rewrite` define how the IMAP server rebuilds a DECnet address that contains quotation marks. The following list describes the possible values:

- **GENERIC**

The address is changed to the SMTP format. For example, on host `widgets.xyzcorp.com`, the message header `From: ORDERS::"j_smith@acme.com"` becomes:

```
From: "ORDERS::"j_smith@acme.com"@widgets.xyzcorp.com
```

- **NONE**

The `From:` line is passed unmodified to the IMAP client. For example:

```
From: ORDERS::"j_smith@acme.com"
```

You cannot reply to this type of mail message because the SMTP server does not accept an address of this form.

- **TRANSFORM**

The IMAP server uses the text inside the quotation marks. For example, the message header `From: ORDERS::"j_smith@acme.com"` becomes:

```
From: j_smith@acme.com
```

5.12.2.6.5. Cluster-Forwarding SMTP Address

With a cluster-forwarding SMTP address, the IMAP server uses the SMTP address within the quotation marks. For example, the message header

```
From: ABCDEF::SMTP%"james.smith@federation.gov"
```

becomes:

```
From: james.smith@federation.gov
```

5.12.2.6.6. All Other Addresses

For all other address formats, the IMAP server changes the entire address to the SMTP format:

- Quotation marks in the address are prefixed with the backslash (`\`) escape character.
- The entire address is placed within quotation marks.
- An at sign (`@`) is appended.

- The value of configuration option Gateway-Node, if defined, is appended; if not, the value of the SMTP substitute domain is appended. If both are undefined, then the name of the local host is appended.

For example, if the substitute domain is `xyz.org`, the message header `From: ABCMTS::MRGATE::"ORDERS::SPECIAL"` becomes:

```
From: "ABCMTS::MRGATE::"ORDERS::SPECIAL"@xyz.org
```

If the configuration option `Ignore-Mail11-Headers` is set to `True` and the address is an SMTP address, the rebuilt `From:` field is not displayed to the user. In this case, the IMAP server sends the actual headers from the body of the mail as the mail headers.

5.12.2.7. Uploaded Messages

You can copy mail messages stored on the local client system to OpenVMS Mail. This action is termed **uploading** and involves the creation of a new OpenVMS Mail message.

When a message is uploaded, OpenVMS Mail treats it as a new mail message, and a “New Mail” broadcast message is issued. You see this message if you also have an OpenVMS VT session open with receipt of broadcast messages enabled.

When a message is uploaded, the entire message is copied along with the header information described in Table 5.7. Note that the additional header information is visible only if you read it with MAIL or if the configuration option `Ignore-Mail11-Headers` is set to `False`.

Table 5.7 describes the typical headers in an uploaded message.

Table 5.7. Header Information in Uploaded Messages

| Header | Value |
|--------|--|
| Body: | The entire SMTP message, including headers. |
| From: | The underscore character (<code>_</code>), followed by the name of the user who is uploading the message |
| To: | The underscore character (<code>_</code>), followed by the name of the user who is uploading the message |
| Subj: | The subject of the uploaded message. |

Chapter 6. Printing Files Using LPR/LPD

The Line Printer/Line Printer Daemon (LPR/LPD) supports the DCL commands PRINT, LPQ, and LPRM for remote printing.

The LPR/LPD service allows you access to print queues on remote hosts and allows users on remote hosts to access print queues on your system.

The following table lists network printing services you can perform and the sections that explain how to use them.

| Capability | Section |
|---|---------|
| Send print jobs to a printer connected to a remote internet host. | 6.1 |
| Display remote print queue status. | 6.2 |
| Cancel print jobs. | 6.3 |
| Receive on local (OpenVMS system) print queues print jobs initiated from a user on a UNIX system. | 6.4 |
| Obtain online help. | 6.5 |

To use TCP/IP Services network printer services, you need the following:

- The name of the remote print queue
- Remote Print Server LPD protocol extensions software you need to use the PRINT / PARAMETERS command
- TCP/IP Services installed and LPR/LPD enabled on your OpenVMS system

Table 6.1 summarizes the commands that control printing features. (For complete command descriptions, see Section 6.6.)

Table 6.1. Network Printing Commands Summary

| DCL Command | UNIX Command | Function |
|-------------|--------------|--|
| PRINT | lpr | Prints files. |
| LPQ | lpq | Displays the status of a remote print queue. |
| LPRM | lprm | Removes jobs from a remote print queue. |

6.1. Printing at Remote Print Queues

Your system manager can configure your system with LPR/LPD network services that allow you to use the DCL command PRINT to send print jobs to a print queue on a remote internet host. The remote host can be a UNIX system or another OpenVMS system running LPR/LPD.

You print a local file at a printer on a remote host by specifying the remote queue name defined on your local host (see your system manager for queue names). LPD copies the file to the appropriate

remote printer's spool directory. A copy of the file to be printed remains in the spooling queue until the printer is ready to print it.

When you enter the DCL command PRINT to send a print job to a remote print queue, you use the /QUEUE qualifier to specify the queue name, plus any of the following qualifiers:

| | | |
|-----------|-------------|------------|
| /AFTER | /BACKUP | /BEFORE |
| /BY_OWNER | /CONFIRM | /COPIES |
| /CREATED | /DELETE | /EXCLUDE |
| /EXPIRED | /FORM | /HEADER |
| /HOLD | /IDENTIFY | /JOB_COUNT |
| /MODIFIED | /NAME | /NOTE |
| /OPERATOR | /PARAMETERS | /PASSALL |
| /PRIORITY | /QUEUE | /SETUP |
| /SINCE | /USER | /WIDTH |

Two of these qualifiers work differently with TCP/IP Services than they do in an OpenVMS environment without TCP/IP Services. These two qualifiers are:

- /FORM
- /PARAMETERS

The following sections discuss the unique features of these qualifiers when used for remote printing.

Note

TCP/IP Services does not support layout definition files for print requests to remote print queues. A layout definition file sets up the layout features: borders, sheet margins, alternating margins, pages per sheet, first page, page order, and page grid.

6.1.1. PRINT /FORM Command

The DCL command PRINT /FORM customizes the look of the printed page. This qualifier associates a form other than the default with the print job.

To find out which forms are defined for your system, enter the following command:

```
$ SHOW QUEUE /FORM
```

To find out the currently mounted form or the default form, enter the following command:

```
$ SHOW QUEUE queue /FULL
```

If the form associated with a remote LPD queue specifies a /WIDTH value that is not the standard 132, LPD sends a "W" card in the job's control file with the width specified in the form.

6.1.2. PRINT /PARAMETERS Command

TCP/IP Services supports numerous options for the DCL command PRINT /PARAMETERS. For example, it supports the PAGE_SIZE option as follows:

```
$ PRINT/PARAMETERS=(PAGE_SIZE=size) /QUEUE=queue_name filename
```

When you enter the PRINT /PARAMETERS=(*option=value*) command, enclose the following in quotation marks:

- Blanks
- Nonalphanumeric characters, including spaces and slashes

You can use the following /PARAMETERS options for both local printing (standard DCL PRINT) and remote printing (DCL PRINT with LPR/LPD network services).

| | | |
|------------------|-----------|-------------|
| DATA_TYPE | NUMBER_UP | PAGE_LIMIT |
| PAGE_ORIENTATION | PAGE_SIZE | SHEET_COUNT |
| SHEET_SIZE | SIDES | |

For a full description of the options supported for DCL local and remote printing, enter the following command.

```
$ HELP PRINT_PARAMETER
```

Note

This help is available only if the DECprint Supervisor (DCPS) software is installed on your system. See your system manager for more information.

The following /PARAMETERS options are supported only for use with remote printing.

| | |
|--------|---------|
| HOST | MAIL |
| NOFLAG | PRINTER |

The options are described in more detail in the following sections.

6.1.2.1. HOST and PRINTER Options

Use the HOST and PRINTER options together to send a print job to any remote host and printer that do not have a specific print queue defined on the local system.

In conjunction with the HOST and PRINTER options, you must also specify the /QUEUE qualifier. The value of /QUEUE should be TCPIP\$LPD_OUT.

For example, the following command specifies that the file PINS.LIS be sent to printer CT_LN05R on remote host BALT:

```
$ PRINT/PARAMETERS=(HOST=BALT, PRINTER=CT_LN05R) /QUEUE=TCPIP$LPD_OUT
PINS.LIS
```

The HOST and PRINTER options allow you to use any available network printers without your system manager having to set up additional LPD remote queues for each of these printers.

Specify the remote host name either by the host name or by its fully qualified domain name (see Section 1.4).

6.1.2.2. /PARAMETERS Qualifier: MAIL Option

The MAIL option causes the remote host to notify you through SMTP mail when the print job completes. The following command specifies the MAIL option:

```
$ PRINT/PARAMETERS=MAIL /QUEUE=DPR_ANSI PINS.LIS
```

6.1.2.3. /PARAMETERS Qualifier: NOFLAG Option

The NOFLAG option suppresses printing of a banner (flag) page at an LPD queue. For information about LPD queues, see the *VSI TCP/IP Services for OpenVMS Management* manual.

The following command specifies the NOFLAG option:

```
$ PRINT/PARAMETERS=NOFLAG /QUEUE=DPR_ANSI PINS.LIS
```

6.1.3. Remote Queue Printing Examples

The following examples show how to use the remote queue printing capabilities of TCP/IP Services.

1. This example sends local file PINS.LIS to the remote print queue defined locally as FAC3_ANSI and requests notification through SMTP when the job completes at the remote printer.

```
$ PRINT /PARAMETERS=MAIL /QUEUE=FAC3_ANSI PINS.LIS
```

2. This example shows how to send a local file to the remote print queue defined locally as OUR_PS for printing at a remote printer. The command specifies that text be printed on both sides of each sheet. The file name is ROUGH.TXT.

```
$ PRINT /QUEUE=OUR_PS /PARAMETER=(SIDES=2) ROUGH.TXT
```

3. This command sends a print job to the remote queue defined locally as YOUR_PS.

```
$ PRINT /QUEUE=YOUR_PS LET.LIS -  
_ $ /PARAMETERS=(DATA_TYPE=POST, PAGE_ORIENTATION=LANDSCAPE, SIDE=2)
```

4. This example sends a print job to Internet host PACE.SATR.N.COM to print on printer K1_PRINTER.

```
$ PRINT /QUEUE=LPD_OUTQ USER$4:[GRANT.FINAN.SALES]ANNUAL.TXT -  
_ $ /PARAMETERS=(HOST=PACE.SATR.N.COM, PRINTER=K1_PRINTER)
```

6.2. Displaying the Status of Jobs in a Remote Print Queue

To display the status of jobs you send to a remote printer, use the LPQ command. The following information is displayed:

- Your name
- Current rank of job in the queue
- Names of the files in job
- Job identifier

- Total size of job in bytes

The following examples show how you can use the LPQ command.

1. This command displays all entries in the LPS40_QUE queue.

```
$ LPQ LPS40_QUE
```

2. This command displays information about job 4 in the print queue named OFFICE_QUE.

```
$ LPQ OFFICE_QUE /ENTRY=4
```

3. This command displays information about jobs 1, 2, and 3 in print queue PEACE_Q.

```
$ LPQ PEACE_Q /ENTRY=(1,2,3)
```

4. This command displays information about user NELSON's jobs in the print queue FRONT_Q.

```
$ LPQ FRONT_Q /USER=NELSON
```

6.3. Removing Jobs from the Print Queue

To remove your jobs from a remote print queue, use the LPRM command. The LPRM command lets you remove the following:

- All of your active jobs
- All jobs, if you have the required privileges
- Selected jobs

The following examples show how you can use the LPRM command.

1. This command deletes job 7 from print queue BASE_Q.

```
$ LPRM BASE_Q /ENTRY=7
```

2. This command deletes jobs 555, 556, and 558 from queue BASE_Q.

```
$ LPRM BASE_Q /ENTRY=(555,556,558)
```

3. In this example, the system manager, who has the required privileges, deletes all jobs from queue MAIN_QUE.

```
$ LPRM /ALL MAIN_QUE
```

6.4. Printing Remote UNIX Files on Local Queues

Your system manager can set up a local print queue to handle print jobs for files sent from a remote UNIX host. To print UNIX files on an OpenVMS printer, the UNIX user enters the `lpr` command. (For more information, see the appropriate UNIX documentation.)

Local queues that are set up to receive UNIX print jobs support layout definition files. These are files are supported only on OpenVMS and are used to set the following layout features: borders, sheet margins, alternating sheet margins, pages per sheet, first page, page order, and page grid.

The following example sends UNIX file `/usr/stanton/recent.cnts` to OpenVMS print queue `REMOTE_QUEUE4` and specifies the formatting defined in the layout file called `layout3`. The `REMOTE_QUEUE4` print queue is set up as a remote queue in the printcap file by the system manager.

```
% lpr -Llayout3 -Premote_queue4 /usr/stanton/recent.cnts
```

6.5. Obtaining Online Help

You can obtain online help for the LPR/LPD network printing services by entering the following commands:

```
$ HELP TCPIP_SERVICES LPR_LPD
$ HELP LPQ
$ HELP LPRM
```

6.6. Command Descriptions

This section provides complete descriptions of the commands you can use to send a print job to a remote printer, monitor remote print jobs, and remove remote print jobs.

LPQ

LPQ — Displays the status of your jobs in a remote print queue. The status information includes: current rank of your job in the queue, names of your queued files, job identifier, and size of jobs in bytes.

Syntax

```
LPQ queue [ /ENTRY=n ]
          [ /HOST=host ]
          [ /PRINTER=remote_printer ]
          [ /USER=user_name ]
```

Parameter

queue

Required.

Queue for which you want status.

Qualifiers

`/ENTRY= n`

Optional. Default: all jobs. You can specify a list of values.

Displays status for the specified jobs.

`/HOST= host`

Optional. Default: host defined in the printcap file.

Displays status for the jobs you sent to the specified host. This is the host you also specified in the `PRINT /PARAMETERS=(HOST= host)` command.

`/PRINTER= remote_printer`

Optional. Default: printer defined in the printcap file.

Displays status for the jobs you sent to the specified remote printer. This is the queue you also specified in the `PRINT /PARAMETERS=(PRINTER= queue)` command.

`/USER= user`

Optional. Default: all users.

Displays status for the jobs sent by the specified user. You can specify a list of values.

Example

1. `$ LPQ LPS40_QUE`

Shows all entries in the LPS40_QUE queue.

2. `$ LPQ MAIN_QUE /ENTRY=4`

Shows information about job 4 in the print queue named MAIN_QUE.

3. `$ LPQ PEACE_8 /ENTRY=(1,2,3)`

Shows information about jobs 1, 2, and 3 in print queue PEACE_8.

4. `$ LPQ 3RD_FLOOR_Q /USER=MILLER`

Shows information about user MILLER's jobs in the print queue called 3RD_FLOOR_Q.

LPRM

LPRM — Removes one or more jobs from a remote print queue.

Syntax

```
LPRM queue {/ALL /ENTRY=n /USER=user_name}
           [/HOST=host]
           [/PRINTER=remote_printer]
```

Parameter

queue

Required.

Print queue with waiting jobs you want to delete.

Qualifiers

`/ALL`

Required, unless you specify `/ENTRY` or `/USER`.

Removes all jobs for all users from the specified queue. Requires `SYSPRV`, `OPER`, or `BYPASS` privilege. Comparable to the UNIX command `lprm -Pqueue -` when performed by the root user on the UNIX system.

`/ENTRY= n`

Required, unless you specify `/ALL` or `/USER`.

Removes the specified job. Specify only your own jobs. You can specify a list of values.

`/USER= user`

Required, unless you specify `/ALL` or `/ENTRY`.

Removes jobs by user name. You can specify a list of values.

`/HOST= host`

Optional. Default: host defined in the `printcap` file.

Removes jobs by host for the host you specified in the `PRINT /PARAMETERS=(HOST=host)` command.

`/PRINTER= remote_printer`

Optional. Default: printer defined in the `printcap` file.

Removes jobs from the remote printer you specified in the `PRINT /PARAMETERS=(PRINTER=queue)` command.

Examples

1. `$ LPRM BASE_Q /ENTRY=7`

Deletes job 7 from print queue `BASE_Q`.

2. `$ LPRM FRONT_Q /ENTRY=(555,556,558)`

Deletes entries 555, 556, and 558 from queue `FRONT_Q`.

Chapter 7. Accessing User Information Using the FINGER Utility

For displaying information about users on remote systems and your local system, TCP/IP Services includes the FINGER utility. For example, you can use the FINGER utility to determine which users are logged on to a system or to refresh your memory about the correct login name to use before using FTP or another service to connect to an account on a remote host.

The FINGER listing can include such information as:

- User name
- Account name
- Program the user is running
- User's home directory
- User's plans, activities, and other information
- User's project

The following table lists the capabilities provided by the FINGER utility and the sections that explain how to use them.

| Capability | Section |
|---|---------|
| Display brief information about all users on a host. | 7.3.1 |
| Display detailed information about one or more specific users on a host. | 7.3.2 |
| Display information about all users logged into an OpenVMS Cluster system. | 7.3.3 |
| Get information from a host that is not directly accessible to your local host. | 7.4 |
| Make planning and project information about yourself available to other FINGER users. | 7.5 |

The FINGER software must be enabled on your local OpenVMS host (see your system manager). If FINGER has not been started, then attempts to use the FINGER command might cause an error message because of missing privileges. You must start the utility before attempting to use it.

7.1. Typing FINGER Commands

Use the following rules for command syntax and wildcards when you enter FINGER command lines.

7.1.1. Wildcards

Wildcards are not accepted for OpenVMS hosts but may be valid for some UNIX hosts.

7.1.2. Qualifiers

Qualifiers to the FINGER command must follow immediately after the command verb and must precede the user or host name. If the qualifier follows the user or host name, the FINGER utility interprets the qualifier as a user name. For example, in the following command, the qualifier /FULL incorrectly appears after the user specification. As indicated by the last line in the display, the FINGER server interprets /FULL as a user login name.

```
$ FINGER ROLLINS /FULL
```

```
Username      Program      Login      Term/Location
ROLLINS       $            Mon 15:02 64626::ROLLINS

Login name: ROLLINS           In real life: Professor Rollins
Account: RES9                 Directory: WORK1$:[ROLLINS]
Last login: Tue 3-MAR-2002 09:05:29
Unread mail: 25
Project: Homeopathic medicine/Silica
No Plan.
Login name: /FULL             In real life: ???
```

The following example shows the correct position of the qualifier (the information displayed now includes user ROLLINS' real name and current program).

```
$ FINGER /FULL ROLLINS
```

```
[stlab1.bastyr.edu]
Username      Real Name      Program      Login      Term/Location
ROLLINS       Ben Rollins    $            Mon 15:02 64606::ROLLINS
              $            Mon 09:42 64606::ROLLINS

Login name: ROLLINS           In real life: Professor Rollins
Account: RES9                 Directory: WORK1$:[ROLLINS]
Last login: Tue 3-MAR-2002 09:05:29
Unread mail: 27
Project: Homeopathic medicine/Silica
No Plan.
```

7.2. Obtaining Online Help

You can obtain online help for the FINGER utility by entering either of the following commands:

```
$ HELP TCPIP_SERVICES FINGER
$ HELP FINGER
```

7.3. Displaying Information about Users

To display information about all users on a remote host, enter the FINGER command followed by the host name (FINGER @ *hostname*). To display more detailed information about a particular user, specify the user name with the host name (format FINGER *username@hostname*). To display information about all users on your local host, enter the FINGER command without specifying a host name. To display detailed information about a specific user on your local host, enter the FINGER command followed by the user name. Table 7.1 summarizes the different ways to display user information.

Table 7.1. Ways of Displaying Information Using the FINGER Command

| If you need ... | Use this command... |
|---|--|
| Brief information about all users on a remote host | FINGER @ <i>hostname</i> |
| Brief information about all users on your local host | FINGER |
| Brief information about all users on your cluster | FINGER/CLUSTER |
| Detailed information about a specific user on a remote host | FINGER <i>username</i> @ <i>hostname</i> |
| Detailed information about several users on a remote host | FINGER <i>user1name</i> @ <i>hostname</i> <i>user2name</i> @ <i>hostname</i> |
| Detailed information about a specific user on your local host | FINGER <i>username</i> |
| Detailed information about several users on your local host | FINGER <i>user1name</i> <i>user2name</i> |
| More detailed information about users on the local host, including their real name and all logins | FINGER/FULL |
| Brief information about all local users and detailed information about a specific local user | FINGER/ALL <i>username</i> |

7.3.1. Displaying Information about All Users

To display brief information about all users on a host, use the FINGER command with the host name only, in the format *@hostname*. If you use the FINGER command alone (without specifying a host name), you receive brief information about all users on your local system. The following example shows how to display brief information about all users on remote host SCIENCE:

```
$ FINGER @SCIENCE
```

```
[science.ucd.edu]
Username      Program      Login      Term/Location
BRADY         $            Thu 07:50 dialin_706_101.ucd.lab.edu
CORRIT        $            Tue 13:30 64334::CORRIT
DAVE          MAIL        Mon 15:02 64334::DAVE
DAWSON        $            Thu 14:57
FLOYD         $            Mon 17:00
KITT          TPU         Mon 16:57 62555::KITT
MIRTH         $            Wed 16:04 UCDVAX::MIRTH
NATALIE       $            Tue 09:23 64222::NATALIE
RAPSONG       $            Mon 18:50 64442::RAPSONG
```

7.3.2. Displaying Detailed Information about Specific Users

To display details about one or more users on a remote host, specify the user name or a list of user names, including the host name with each user name, as shown in the examples that follow. To display more information about users on your local host, specify the user names without a host name. The information about each user includes the following items in addition to the user (login) name, program, login time, and terminal/location that is returned in the default, brief display:

- Login name

- Full name (real name)
- Working directory
- Last (previous) login
- Number of unread mail messages
- Plans and project, if the user has made the information available

The following examples show how to display information about specific users.

1. This example shows how to receive detailed information about user HOWE on host BEARINGS. The second line of information indicates user HOWE is logged in and using the OpenVMS Mail utility.

```
$ FINGER HOWE@BEARINGS

[bearings.us.beacorp.com]
Username      Program      Login      Term/Location
HOWE          MAIL         Mon 15:02  84640::HOWE

Login name: HOWE          In real life: Abe Howe
Account: INVENT          Directory: DISK$1:[HOWE]
Last login: Tue  3-MAR-2002 10:15:39
No unread mail
Project: Inventory
No Plan.
```

2. This example displays information about several specific users on a remote host. The command displays detailed information about users HOWE and JESSE on host BEARINGS, and user BILLINGS on UNIX host class. Note that user HOWE is not currently logged in to host BEARINGS. JESSE is logged in, so FINGER displays a line of information for JESSE, including the program JESSE is using (DCL at present) and the time of login.

```
$ FINGER HOWE@BEARINGS JESSE@BEARINGS BILLINGS@CLASS

[bearings.us.beacorp.com]
Login name: HOWE          In real life: Abe Howe
Account: INVENT          Directory: DISK$1:[HOWE]
Last login: Tue  3-MAR-2002 10:15:39
No unread mail
Project: Inventory
No Plan.
[bearings.us.beacorp.com]
Username      Program      Login      Term/Location
JESSE         $            Thu 09:24

Login name: JESSE          In real life: JESSE BOYD
Account: PLAN3            Directory: DISK$1:[JESSE]
Last login: Mon  2-MAR-2002 16:48:50
Unread mail: 1
Project: Planning
Plan:
Next phase: December

E-mail: jesse@bearings.us.beacorp.com
```

Phone: 526-5444

```
[class.ucb.beacorp.com]
Login name: billings      (messages off) In real life: M. T. Billings
Office: BLDG2-2, 555-7873      Home phone: 111-222-3333
Directory: /usr/users/billings      Shell: /usr/bin/csh
On since Jan 17 14:33:06
    on :0
On since Jan 17 14:33:13      15 days Idle Time
    on tty1
On since Jan 17 14:33:13      2 days 23 hours Idle Time
    on tty2
On since Feb  4 13:13:50      2 days 23 hours Idle Time
    on tty5
No Plan.
```

3. This command displays detailed information about one or more specific users and brief information about all other users who are logged in to a remote host. For example:

```
$ FINGER DALB@BEARINGS @BEARINGS
Username      Program      Login      Term/Location

Login name: DALB      In real life: Bob Dalb
Account: ENG_3      Directory: WORK1$:[DALB]
Last login: Thu  5-MAR-2002 16:26:06
No unread mail
Project: TCP/IP Services for OpenVMS
No Plan.

BRADY      $      Thu 07:50 dialin_706_101.lkg.dec.com
BYRD      $      Mon 17:00
CORTEZ      $      Tue 13:30 60121::CORTEZ
DALB      TCP/IP$FINGER      Thu 16:26 54242::DALB
KURT      $      Mon 16:57 32556::KURT
LARSON      SHWCLSTR      Mon 17:01
MUELLER      $      Wed 16:04 VALVE::MUELLER
NASAN      $      Tue 09:23 44500::NASAN
PHILLIPS      $      Tue 02:42 REMHST::PHILLIPS
ROLLINS      $      Mon 18:50 46142::ROLLINS
SIMMEL      MAIL      Thu 14:12 VALVE::SIMMEL
```

4. This command displays detailed information about a specific user and brief information about the remaining logged-in users on a local host. Note use of the /ALL qualifier which displays specific information about user HOWE at the local host plus brief information about all other users logged in. The output of this command is similar to that shown in the preceding example.

```
$ FINGER/ALL HOWE
```

7.3.3. Displaying Information about Users on Your Cluster

To display information about users on all nodes in your local OpenVMS Cluster, use the /CLUSTER qualifier, as in the following examples.

1. This example shows the default display for the FINGER/CLUSTER command.

```
$ FINGER/CLUSTER
```

| Username | Node | Program | Login | Term/Location |
|----------|--------|---------------|-----------|---------------------|
| ANND | UCDAXP | \$ | Mon 17:00 | |
| BRADY | UCDAXP | \$ | Thu 07:50 | dialin_101.ads.com |
| CALLING | UCDALP | RTPAD | Thu 14:50 | |
| CALLING | UCDAXP | \$ | Thu 14:57 | |
| CURREN | UCDAXP | \$ | Tue 13:30 | 84051::CURREN |
| DOBB | UCDWON | TCPIP\$FINGER | Mon 11:50 | |
| GILBERT | UCDVAX | MAIL | Thu 14:34 | pcgil.admin.ucd.edu |
| IMMIN | UCDALP | \$ | Wed 16:21 | BIXBY::IMMIN |
| KITT | UCXAXP | \$ | Mon 16:57 | 62555::KITT |
| KITTEL | UCXALP | \$ | Thu 14:12 | AGGIE::KITTEL |
| LEVINE | UCDUNI | DECW\$SESSION | Thu 10:50 | |
| LEVINE | UCDALP | TCPIP\$UCP | Thu 10:30 | llevine.ads.com |
| MILLER | UCDALP | TCPIP\$FINGER | Thu 15:00 | AGGIE::MILLER |
| MIRTH | UCDVAX | \$ | Tue 17:09 | |
| MIRTH | UCDVAX | RTPAD | Mon 17:27 | |
| NATALIE | UCDAXP | \$ | Tue 09:23 | 64222::NATALIE |
| POFF | UCXAXP | \$ | Tue 02:42 | AGGIE::POFF |
| RAPSONG | UCDAXP | \$ | Mon 18:50 | 64442::RAPSONG |
| TIBBS | AGGIE | \$ | Tue 20:43 | UCXAXP::TIBBS |

2. This example displays each user's real name and every login to cluster members by including the / FULL qualifier.

\$ FINGER/CLUSTER/FULL

| Username | Real Name | Node | Program | Login | Term/Location |
|----------|-------------------|--------|---------------|-----------|--------------------|
| ANND | Ann Darin | UCDAXP | \$ | Mon 17:00 | |
| | | UCDAXP | \$ | Tue 11:51 | |
| BRADY | Robert Brady | UCDAXP | \$ | Thu 07:50 | dialin_101.ads.com |
| | | UCDWON | \$ | Fri 08:31 | |
| CALLING | Alvin Calling | UCDALP | RTPAD | Thu 14:50 | |
| | | UCDAXP | \$ | Thu 14:57 | |
| CURREN | Steve Curren | UCDAXP | \$ | Tue 13:30 | 84051::CURREN |
| | | UCDVAX | \$ | Tue 14:20 | |
| DOBB | Barry Dobb | UCDWON | TCPIP\$FINGER | Mon 11:50 | |
| | | UCDAXP | \$ | Wed 09:20 | |
| GILBERT | Joanne Gilbert | UCDVAX | MAIL | Thu 14:34 | pcgil.ads.com |
| IMMIN | Armen Immin | UCDALP | \$ | Wed 16:21 | BIXBY::IMMIN |
| KITT | Evelyn Kitt | UCXAXP | \$ | Mon 16:57 | 62555::KITT |
| | | UCDALP | SEARCH | Mon 16:43 | 62555::KITT |
| KITTEL | Herb Kittel | UCXALP | \$ | Thu 14:12 | AGGIE::KITTEL |
| LEVINE | Larry Levine | UCDUNI | DECW\$SESSION | Thu 10:50 | |
| | | UCDALP | TCPIP\$UCP | Thu 10:30 | slevine.ads.com |
| MILLER | Paul Miller | UCDALP | TCPIP\$FINGER | Thu 15:00 | AGGIE::MILLER |
| MIRTH | Phil Anson | UCDVAX | \$ | Tue 17:09 | |
| | | UCDVAX | RTPAD | Mon 17:27 | |
| NATALIE | Natalie Beardsley | UCDAXP | \$ | Tue 09:23 | 64222::NATALIE |

```

POFF      Pamela Offred      UCXAXP $      Tue 02:42 AGGIE::POFF
RAPSONG   Aaron Feller      UCDEXP $      Mon 18:50
64442::RAPSONG
TIBBS     Eugene Tibbs      AGGIE $      Tue 20:43
UCXAXP::TIBBS

```

7.4. Forwarding Information from Host to Host

If your host does not have a direct connection to a remote host, you can use a forwarding host to get the information about users on that remote host. Your local host must be able to connect directly to the forwarding host, and the forwarding host must be able to connect directly to the destination. Specify the destination host and the forwarding host in the following format: *username@destination_host@forwarding_host*. For example, system UNION.CTSTATEU.EDU is not directly reachable, but you can get information from it indirectly through a gateway named U-GW.PA.ABCORP.COM. To get information about user JONES on host UNION.CTSTATEU.EDU, enter the following command:

```
$ FINGER JONES@UNION.CTSTATEU.EDU@U-GW.PA.ABCORP.COM
```

By default, the FINGER server does not allow queries to be forwarded from one host to another. To enable forwarding on the FINGER server, see your system manager.

7.5. Making Your Information Available to Other Users

You can use the FINGER utility to display a user's project and plans. The project (a single line of text) indicates the user's current project, work assignment, or work group. The user's plans can include several lines of information, such as where the user will be throughout the week, what the user plans to accomplish during the week, or even such information as the user's web site, e-mail address, and telephone number, as in the following example:

```

I will be in my office Monday through Wednesday working at the S.F. lab.
On Thursday and Friday, I will be at UC Irvine for a conference.
Web site http://bio.ucd.edu/peters/r_peters.html

```

If you want to make such information about yourself available to other users through the FINGER utility, create the following files in your home directory and add the appropriate information:

| | |
|-----------|--|
| . PLAN | A file that contains your plans, whereabouts, and other information you want to have displayed. The file can contain more than one line. |
| . PROJECT | A file that specifies your project or work group. The file can contain only one line. |

7.6. Command Description

To use FINGER commands, enter them at the DCL prompt.

This section provides a complete description of the FINGER command, its parameters, and its qualifiers.

FINGER

FINGER — Displays the following information about users on a host: brief listings of all users on a host, detailed listings about specific users, and listing of users on a cluster. Specifying the FINGER command without a user or host specification displays information about users logged in on your local system.

Syntax

FINGER [/ALL | /CLUSTER | /FULL] [*username*][@ *hostname*]

Parameters

username

Optional. Required for detailed information about a user.

Specify the user login name. For information about a user on your local system, do not include the @ *hostname*. For information about a user on a remote system, include the host name (*username*@*hostname*).

@ hostname

Optional. Required for information about users on a remote system.

For information about a specific user on a remote host, include the user name with the host name (*username*@*hostname*). For information about all users on the remote host, specify the host name only (@*hostname*). Omit the host name to display information about users on your local host.

Qualifiers

/ALL

Optional. Use when specifying a local user name. The /ALL qualifier immediately follows the FINGER command.

Displays a brief listing of all users in addition to detailed information about any specified users. Use this qualifier primarily for displaying information about users on the local host. The /ALL qualifier is ignored by most remote FINGER servers when you specify a remote host name in the command line. To display brief information about all users on a remote host in addition to detailed information about specific users, specify the *user*@*hostname* format for each user, along with @*hostname* (to list brief information about all users). Separate each *user*@*hostname* and @*hostname* specification with a space.

/CLUSTER

Optional. The /CLUSTER qualifier must immediately follow the FINGER command. Do not specify a remote host name with this qualifier.

Displays information about all users logged in to the local OpenVMS Cluster system.

/FULL

Optional. The /FULL qualifier must immediately follow the FINGER command.

Displays detailed information, such as the user's real name and all the user's logins. (Without /FULL, the display includes the last login only.) Use this qualifier primarily for displaying information about users on the local host.

Examples

1. \$ FINGER FRANKEL@KCRA

```

Username      Program      Login      Term/Location
FRANKEL      $           Mon 15:10  KCRA::FRANKEL

Login name:   frankel           In real Life:  Sam Frankel
Account:     CC_Y9M           Directory:    WORK1$:[FRANKEL]
Last login:  Mon 30-MAR-1998 13:10:22
No unread mail
No plan

```

Displays detailed information about user FRANKEL at host KCRA.

2. \$ FINGER @OXYGEN

```

[oxygen.gp.org]
Username      Program      Login      Term/Location
BARD          $           Mon 17:00
CASON        LSEDIT      Thu 14:57
CORR          $           Tue 13:30  24151::CORR
DUDLEY        $           Mon 15:02  24646::DUDLEY
GRAND         $           Thu 07:50  NITROGEN::GRAND
KURT          $           Mon 16:57  22556::KURT
KYLIE         MAIL        Thu 14:12  ELEMENT::KYLIE
MYRA          $           Wed 16:04  BIGVAX::MYRA
NASON         $           Tue 09:23  24200::NASON
PHILLIPS      $           Tue 02:42  BIGALP::PHILLIPS
RAWLINGS      $           Mon 18:50  24042::RAWLINGS

```

Displays brief information about users logged in to host OXYGEN.

3. \$ FINGER/FULL

```

Username      Real Name      Program      Login      Term/Location
BAIRD         Randall Baird  $           Mon 17:00
CARR          Rich Carr      LSEDIT      Thu 14:57
              SHWCLSTR      Mon 17:01
CORTEZ        Julia Cortez  $           Tue 13:30  23441::CORTEZ
DANBOY        Dan Keller     $           Thu 16:12  ogrady.ucsb.edu
GANDHI        T.J. Gandhi   TPU         Mon 16:57  12556::GANDHI
              TPU         Tue 15:27  12556::GANDHI
LIMO          Michael Limorley
              MAIL        Thu 14:12  TOPDAY::LIMO
              LSEDIT      Thu 19:03  TOPDAY::LIMO
MENNING       Mark Menning  $           Wed 16:04  TOPDAY::MENNING
              $           Mon 18:58  HAPDAY::MENNING
NELSON        Anne Nelson   $           Tue 09:23  22200::NELSON
ROBERTS       Michael Roberts
              $           Mon 18:50  22042::ROBERTS
              $           Mon 18:34  HAPDAY::ROBERTS

```

Displays the real name and all logins for each user.

4. \$ FINGER/CLUSTER

| Username | Node | Program | Login | Term/Location |
|-----------|--------|---------|-----------|----------------|
| SMITH | MOUNTB | TPU | Fri 09:47 | MOUNTB::SMITH |
| JONES | MOUNTC | \$ | Tue 18:02 | |
| BROWN | MOUNTC | \$ | Mon 17:04 | |
| TAYLOR | MOUNTB | EDT | Thu 15:59 | |
| CROSBY | MOUNTC | RTPAD | Thu 14:59 | |
| CARPENTER | MOUNTB | \$ | Wed 17:23 | MOUNTB::SYSTEM |
| BLACK | MOUNTC | \$ | Tue 10:42 | MOUNTC::BLACK |

Displays information about all users on all members of the cluster.